

PRODUCT SPECIFICATION

Part Number
PDC36-CxDxxx

Details

- 0.36" (9.10mm) LED Display
- 1 Digit, 7 Segment
- Common Anode or Common Cathode
- AlInGaP and InGaN dice used

Features

- Low power consumption
- RoHS Compliant
- Gray Face or Black Face with White Segments
- Easy mounting on PCB or socket

Mechanical Dimensions

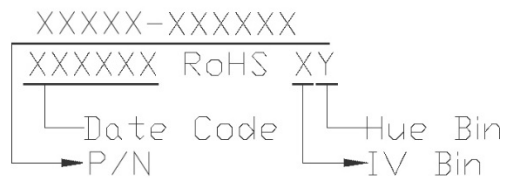
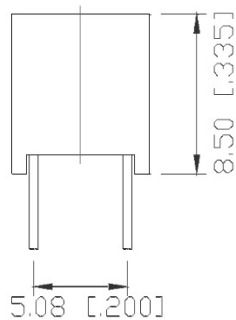
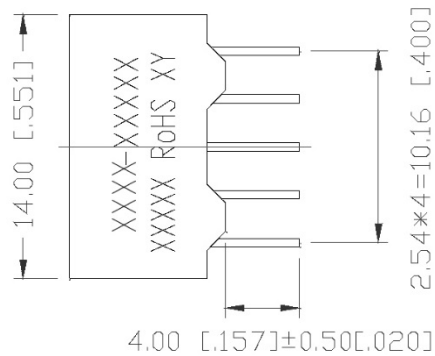
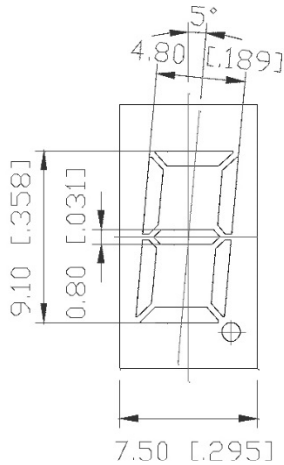

Notes:

1. All pins are $0.45[.018] \pm 0.1[.004]$
2. Dimension in millimeter [inch], tolerance is $\pm 0.25 [0.010]$ and angle is $\pm 1^\circ$ unless otherwise noted.
3. Bending $\leq \text{Length} * 1\%$.
4. Specifications subject to change without notice





Device Selection Guide

Model Number	Chip		Description
	Material	Emitting Color	
PDC36-CxDG05	InGaN	True Green	Common Anode or Common Cathode
PDC36-CxDG17	AlInGaP	Yellow Green	
PDC36-CxDY04		Yellow	
PDC36-CxDA11		Amber	
PDC36-CxDR02		Orange-Red	
PDC36-CxDR11		Red	
PDC36-CxDR21		Deep Red	

Absolute Maximum Ratings at Ta=25 °C

Parameter	Symbol	Rating		Unit
		G17/Y04/A11/R02/R11/R21	G05	
Power Dissipation per Dice	PAD	70	114	mW
Derating Liner from 25°C per Dice	--	0.33	0.4	mA/°C
Continuous Forward Current Per Dice	IAF	25	30	mA
Peak Current Per Dice (duty cycle 1/10, 1KHz)	IPF	90	100	mA
Reverse Voltage Per Dice	VR	5	5	V
Electrostatic Discharge (HBM)	ESD	/	1000	V
Operating Temperature	Topr	-35~+85		°C
Storage Temperature	Tstg	-35~+85		°C

Solder Conditions: 1/16 inch below seating plane for 3-5 seconds at 260°C.



Electrical and Optical Characteristics at Ta=25 °C

Parameter	Symbol	Chip	Min.	Typ.	Max.	Unit	Condition
Forward Voltage Per Segment	VF	G05	--	3.2	3.8	V	IF=20mA
		G17/Y04/A11/R02/R11/R21	--	2	2.8		
Luminous Intensity Per Segment	Iv	G05	--	150	--	mcd	IF=10mA
		G17	--	9	--		
		Y04	--	38	--		
		A11	--	48	--		
		R02	--	23	--		
		R11	--	16	--		
Peak Emission Wavelength / Dominant Wavelength	$\lambda P/\lambda d$	G05	--	*525	--	nm	IF=20mA
		G17	--	572/570	--		
		Y04	--	592/590	--		
		A11	--	612/605	--		
		R02	--	632/625	--		
		R11	--	644/630	--		
Reverse Current	IR		--	--	100	μ A	VR=5V
Luminous Intensity Matching Ratio	Iv-m		--	--	2:1	--	IF=10mA



Luminous General lv Bin Grade (IF = 10mA)

Color Rank Limits (IF = 20mA)

Remark: Unit=mcd

*Tolerance: ±20%

Remark: Unit=nm

*Tolerance: ±1

● Pure Green (G05)

P	Q	R
70.555	112.889	180.623
I	I	I
112.888	180.622	288.996

1	2	3	4	5
515.0	518.0	520.0	522.0	524.0
I	I	I	I	I
518.0	520.0	522.0	524.0	527.0

● Yellow Green (G17)

H	J	K
4.204	6.727	10.764
I	I	I
6.726	10.763	17.223

0	1	2	3	4
567.5	569.5	570.5	571.5	573.0
I	I	I	I	I
569.5	570.5	571.5	573.0	575.0

● Yellow (Y04)

L	M	N
17.224	27.559	44.096
I	I	I
27.558	44.095	70.554

1	2	3	4	5
583.0	585.0	587.0	589.0	591.0
I	I	I	I	I
585.0	587.0	589.0	591.0	593.0

● Amber (A11)

M	N	P
27.559	44.096	70.555
I	I	I
44.095	70.554	112.888

● Orange-Red (R02)

K	L	M
10.764	17.224	27.559
I	I	I
17.223	27.558	44.095

● Red(R11)

J	K	L
6.727	10.764	17.224
I	I	I
10.763	17.223	27.558

● Deep Red (R21)

J	K	L
6.727	10.764	17.224
I	I	I
10.763	17.223	27.558

All Light-On Segments Feature & Pad Position

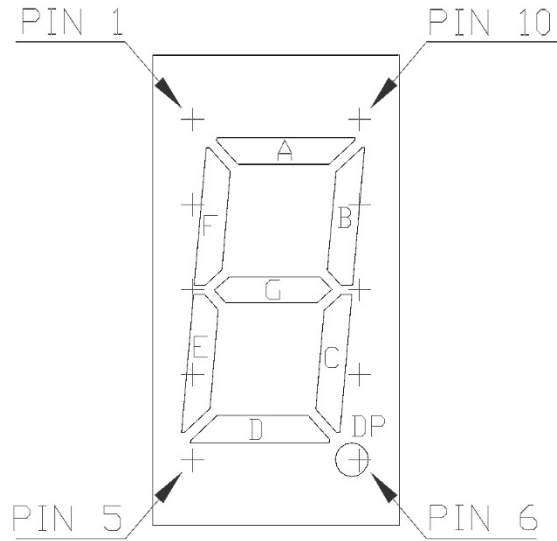

Internal Circuit Diagram

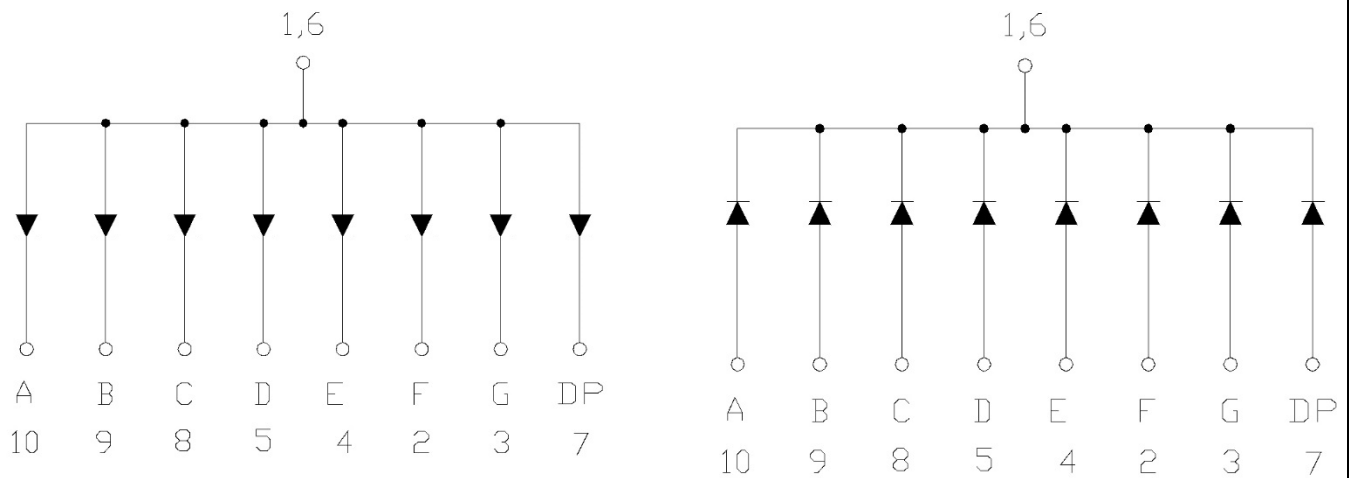

Typical Electrical / Optical Characteristic Curves

- (Ta = 25°C Unless Otherwise Noted)

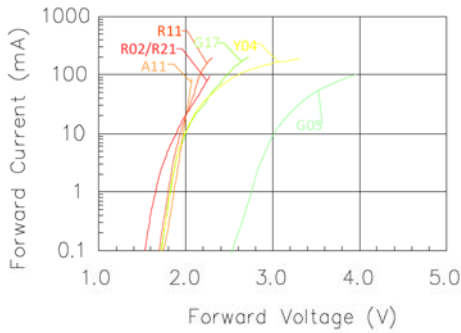

Fig 1. Forward Current vs. Forward Voltage

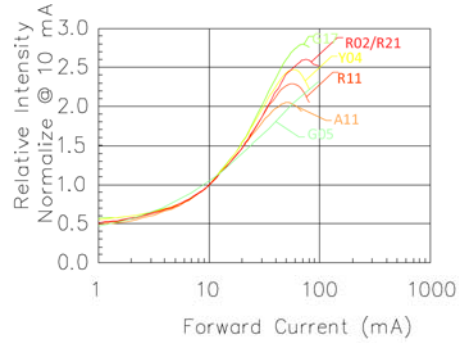

Fig 2. Relative Intensity vs. Forward Current

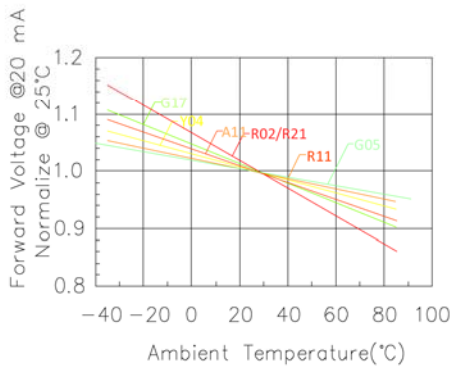

Fig 3. Forward Voltage vs. Temperature

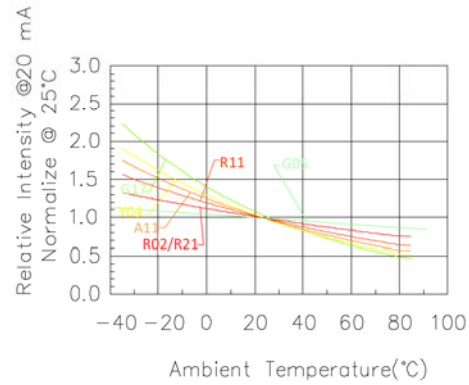

Fig 4. Relative Intensity vs. Temperature

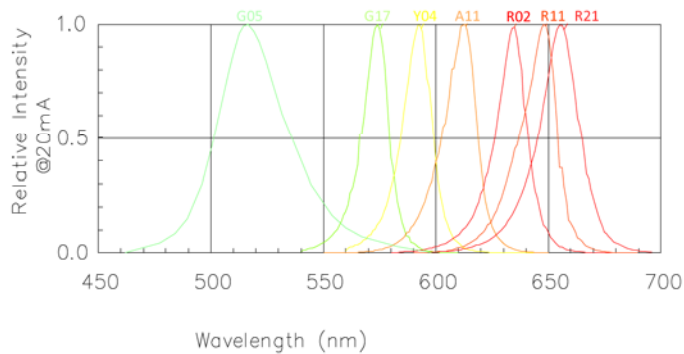

Fig 5. Relative Intensity vs. Wavelength

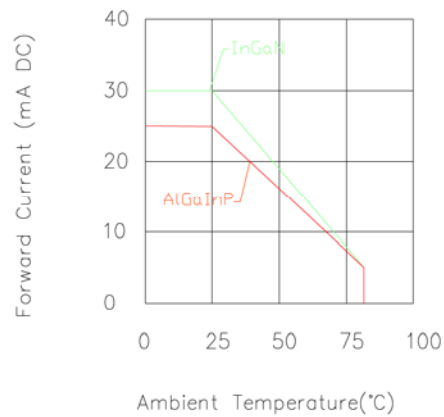

Fig 3. Forward Current vs. Ambient Temperature

Precautions for Use

1. Recommended soldering conditions

a. Wave soldering

- i. Basic SPEC is ≤ 5 sec. When 260°C . If temperature is higher, time should be shorter ($+10^{\circ}\text{C} \rightarrow -1\text{sec.}$).

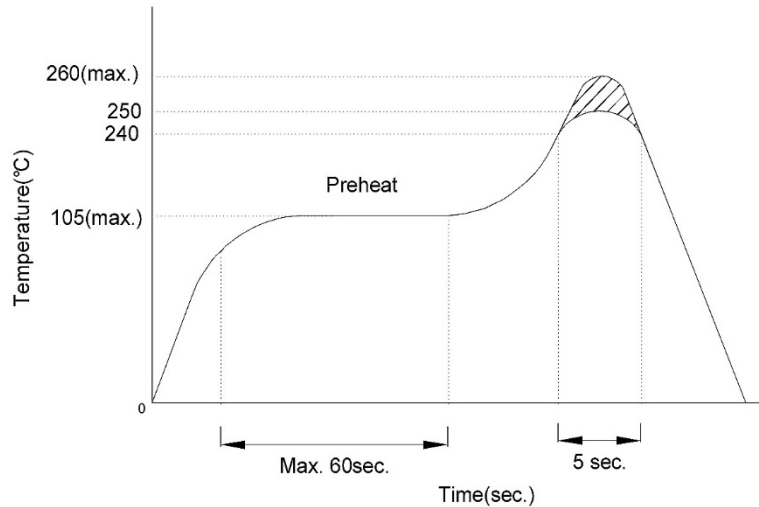

2. Soldering Iron:

- a. Power dissipation of iron should be smaller than 15W and temp should be controllable. Soldering temperature should be under 260°C , time ≤ 3 sec.

Packing Dimensions

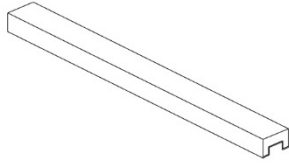

35 PCS Per Tube
Tube Size:
L520*W8.2*H13.8 mm

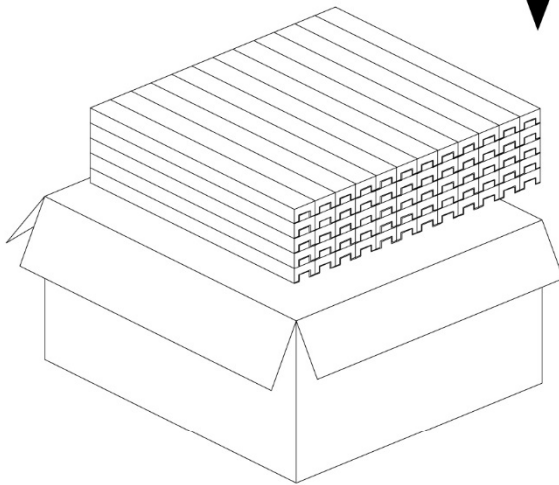

208 Tubes Per Inner Box
Total Q'TY: 7280 Pcs
Box Size:
L530*W265*H155 mm

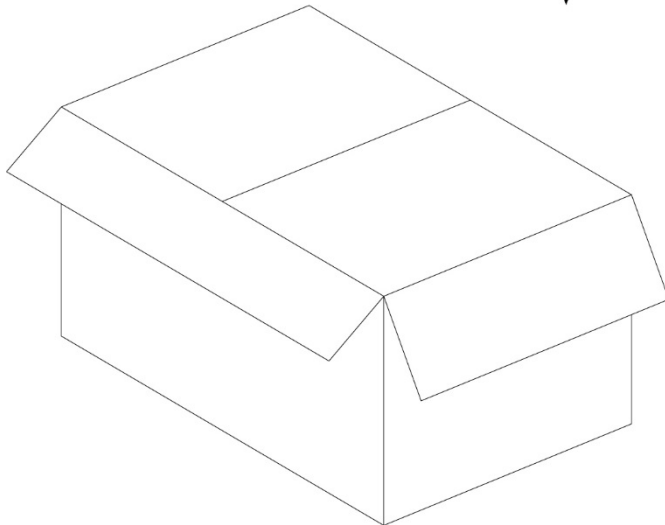

2 Inner Boxes Per Carton.
Total Q'TY: 14560 Pcs
Box Size:
L530*W345*H290 mm



Customer Approval Signatures	Approved By	Checked By	Prepared By

Record Of Revisions			
Rev.	Comments	Page	Date
0	Released Spec	--	08/20/13