

# PRODUCT SPECIFICATION

*Part Number*  
**PDC40SM-CxDxxx**

## Details

- .40" (10.16mm) Surface Mount LED Display
- 1 Digit, 7 Segment
- Common Anode or Cathode
- AlInGaP or InGaN dice used

## Features

- Low power consumption
- RoHS Compliant
- Gray Face, White Segments or Black Face, White Segments
- Easy mounting on PCB or socket

## Mechanical Dimensions

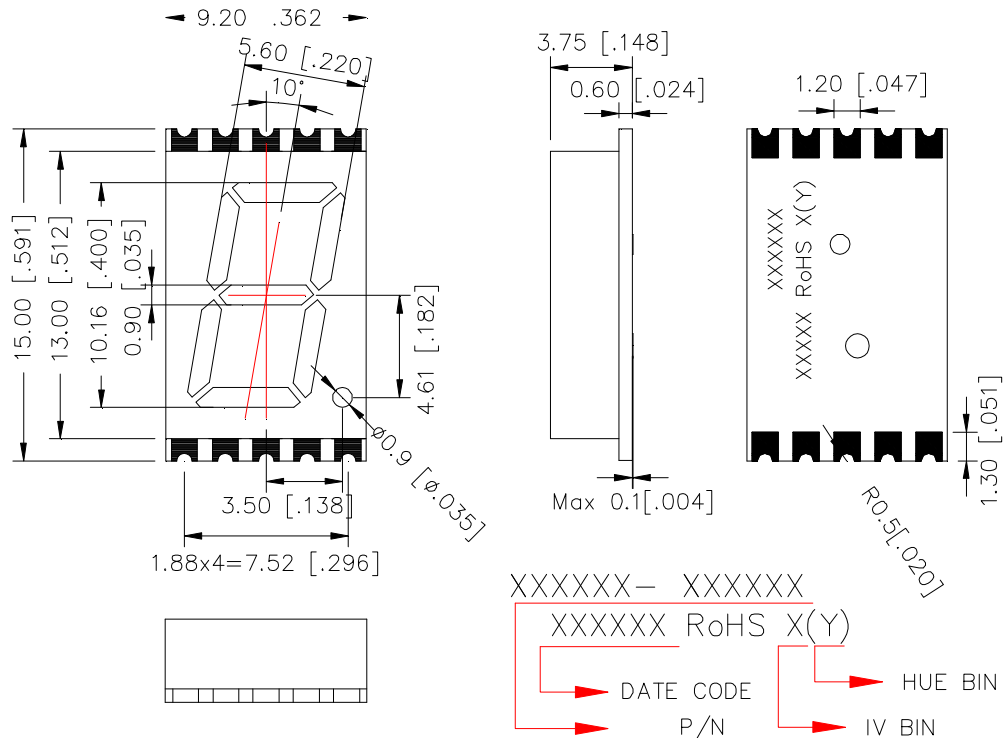

## Notes:

1. Dimensions in millimeters [inch], and tolerance is  $\pm 0.25$  [0.010] and angle is  $\pm 1^\circ$  unless otherwise noted.
2. Bending  $\leq$  Length\*1%
3. All pins are 0.50 by 0.30
4. Specifications subject to change without notice





**Device Selection Guide**

Model Number	Chip		Description	Note
	Material	Emitting Color		
PDC40SM-CxDG05	InGaN	True Green	Common Cathode x=C / Common Anode x=A	Add "BFWS" to end of part number for Black Face, White Segment version
PDC40SM-CxDG17	AlInGaP	Yellow Green		
PDC40SM-CxDY04		Yellow		
PDC40SM-CxDA11		Amber		
PDC40SM-CxDR02		Orange-Red		
PDC40SM-CxDR11		Red		
PDC40SM-CxDR21		Deep Red		

**Absolute Maximum Ratings at Ta=25°C**

Parameter	Symbol	Rating		Unit
		G17/Y04/A11/R02/R11/R21	G05	
Power Dissipation per Dice	PAD	70	114	mW
Derating Liner from 25°C per Dice	--	0.33	0.4	mA/°C
Continuous Forward Current Per Dice	IAF	25	30	mA
Peak Current Per Dice (duty cycle 1/10, 1KHz)	IPF	90	100	mA
Reverse Voltage Per Dice	VR	5	5	V
Electrostatic Discharge (HBM)	ESD	/	1000	V
Operating Temperature	Topr	-40~+105		°C
Storage Temperature	Tstg	-40~+105		°C

**Electrical and Optical Characteristics at Ta=25°C**

Parameter	Symbol	Chip	Min.	Typ.	Max.	Unit	Condition
Forward Voltage Per Segment	VF	G05	--	3.2	3.8	V	IF=20mA
		G17/Y04/A11/ R02/R11/R21	--	2	2.8		
Luminous Intensity Per Segment	Iv	G05	--	47	--	mcd	IF=10mA
		G17	--	2	--		
		Y04	--	13	--		
		A11	--	13	--		
		R02	--	5	--		
		R11	--	4	--		
		R21	--	4	--		
Peak Emission Wavelength / Dominant Wavelength	$\lambda_P/\lambda_d$	G05	--	*525	--	nm	IF=20mA
		G17	--	572/570	--		
		Y04	--	592/590	--		
		A11	--	612/605	--		
		R02	--	632/625	--		
		R11	--	644/630	--		
		R21	--	660/645	--		
Reverse Current	IR		--	--	100	$\mu$ A	VR=5V
Luminous Intensity Matching Ratio	Iv-m		--	--	2:1	--	IF=10mA

### Typical Electrical/Optical Characteristic Curves

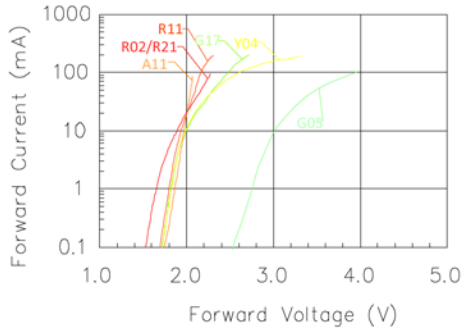

Fig 1. Forward Current vs. Forward Voltage

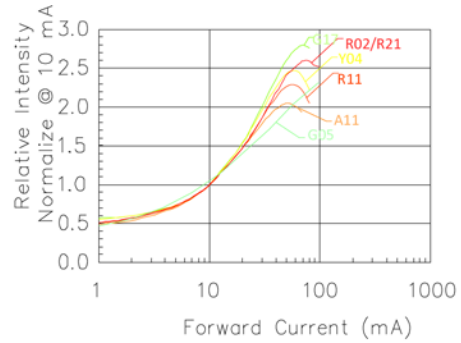

Fig 2. Relative Intensity vs. Forward Current

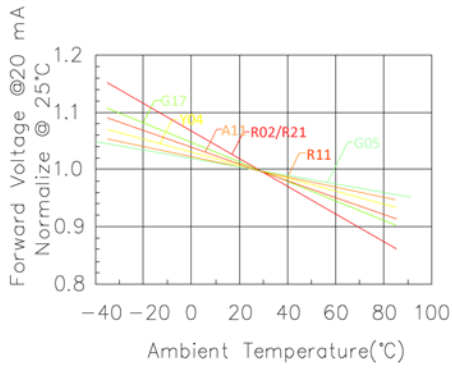

Fig 3. Forward Voltage vs. Temperature

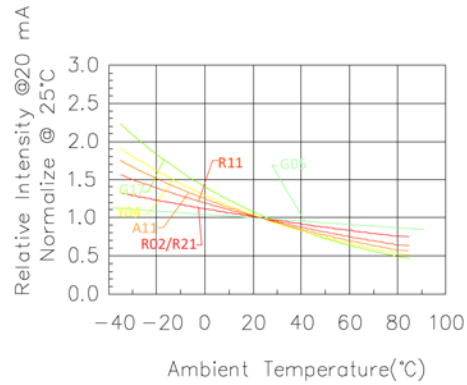

Fig 4. Relative Intensity vs. Temperature

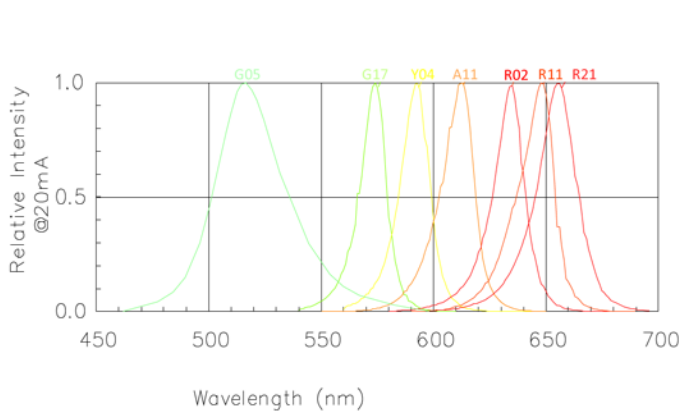

Fig 5. Relative Intensity vs. Wavelength

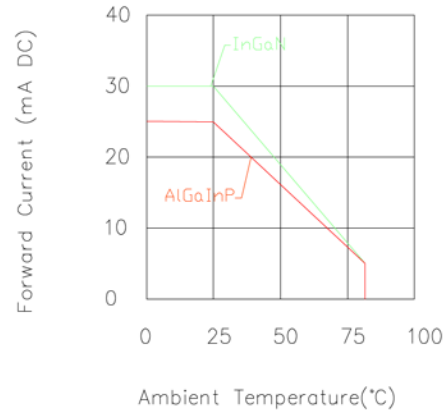

Fig 3. Forward Current vs. Ambient Temperature



**Luminous General lv Bin Grade (IF = 10mA)**

**Color Rank Limits (IF=20mA)**

Remark: Unit=mcd

\*Tolerance: ±20%

Remark: Unit=nm

\*Tolerance: ±1

● Pure Green(G05)

M	N	P
27.559	44.096	70.555
I	I	I
44.095	70.554	112.888

1	2	3	4	5
515.0	517.0	519.0	521.0	523.0
I	I	I	I	I
517.0	519.0	521.0	523.0	525.0

● Yellow Green(G17)

E	F	G
1.025	1.641	2.627
I	I	I
1.640	2.626	4.203

0	1	2	3	4
567.5	569.5	570.5	571.5	573.0
I	I	I	I	I
569.4	570.4	571.4	572.9	575.0

● Yellow (Y04)

J	K	L
6.727	10.764	17.224
I	I	I
10.763	17.223	27.558

1	2	3	4	5
583.0	585.0	587.0	589.0	591.0
I	I	I	I	I
585.0	587.0	589.0	591.0	593.0

● Amber (A11)

J	K	L
6.727	10.764	17.224
I	I	I
10.763	17.223	27.558

● Orange (R02)

G	H	J
2.627	4.204	6.727
I	I	I
4.203	6.726	10.763

● Red (R11)

F	G	H
1.641	2.627	4.204
I	I	I
2.626	4.203	6.726

● Deep Red (R21)

F	G	H
1.641	2.627	4.204
I	I	I
2.626	4.203	6.726

*All Light-On Segments Feature & Pad Position*

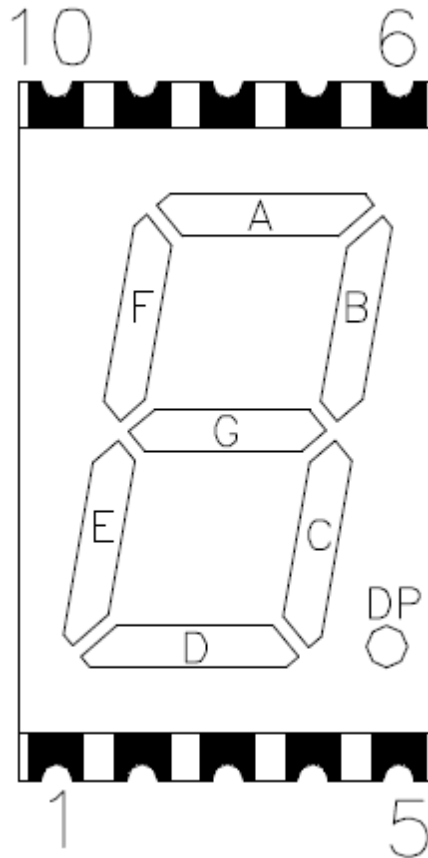

*Internal Circuit Diagram*

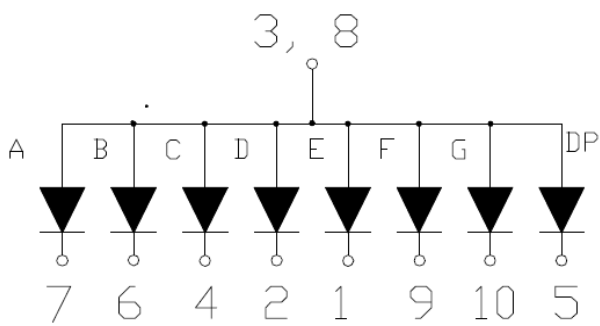

**Common Anode**

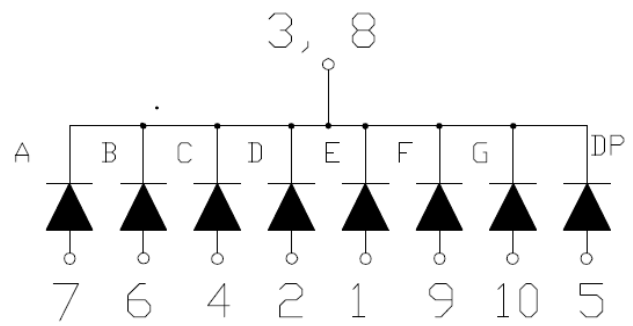

**Common Cathode**

### Precautions for Use

#### 1. Recommended soldering conditions

##### 1.1. Wave soldering

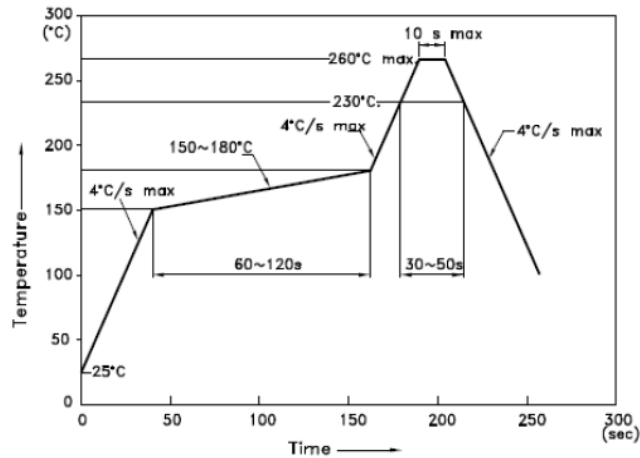

**NOTES:**

1. We recommend the reflow temperature 245°C(+/-5°C). The maximum soldering temperature should be limited to 260°C.
2. Don't cause stress to the epoxy resin while it is exposed to high temperature.
3. Number of reflow process shall be 2 times or less.

##### 1.2. Recommended Soldering Pad:

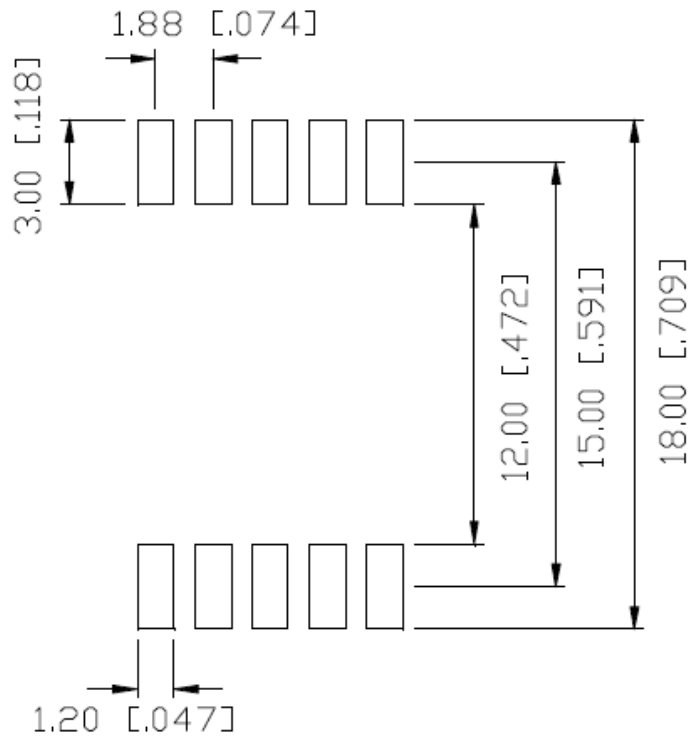

### Reel Dimensions

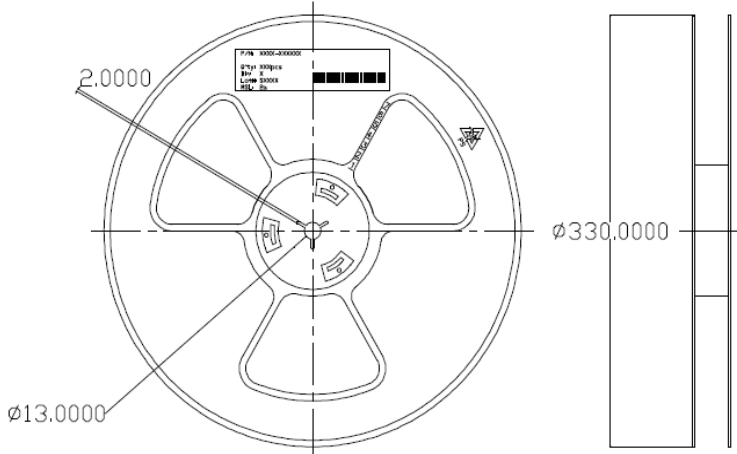

### Packing Dimensions

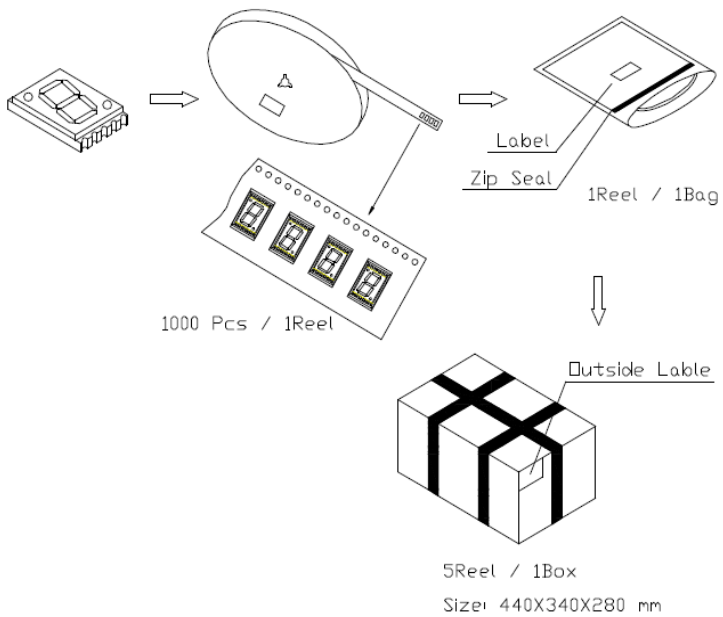

Note: 1. Specifications subject to change without notice.



