

PRODUCT SPECIFICATION

Part Number
PDC52-CxDxxx

Details

- 0.52" (13.20mm) Display
- 1 Digit, 7 Segment
- Common Anode or Cathode
- AllInGaP or InGaN dice used

Features

- Low power consumption
- RoHS Compliant
- Gray Face, White Segments or Black Face, White Segments
- Easy mounting on PCB or socket

Mechanical Dimensions

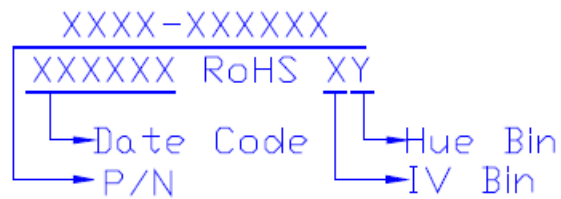
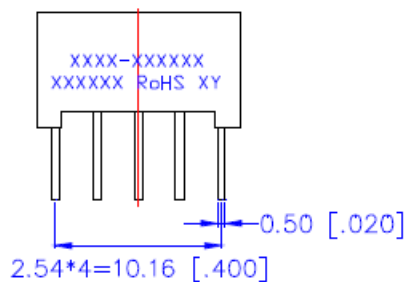
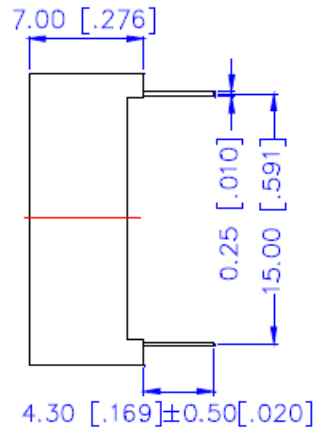
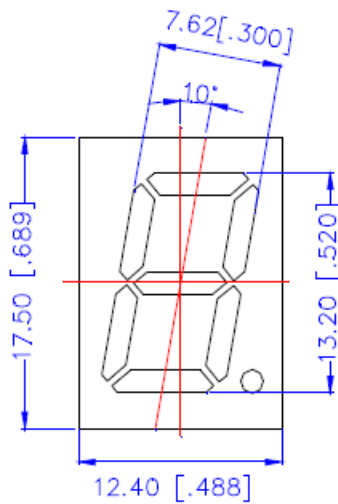

Notes:

1. Dimensions in millimeters [inch], and tolerance is ± 0.25 [.010] and angle is $\pm 1^\circ$ unless otherwise noted.
2. Bending \leq Length*1%
3. All pins are 0.50 by 0.3
4. Specifications subject to change without notice



Device Selection Guide

Model Number	Chip		Description	Note
	Material	Emitting Color		
PDC52-CxDG05	InGaN	True Green	Common Cathode x=C / Common Anode x=A	Add "BFWS" to end of part number for Black Face, White Segment version
PDC52-CxDG17	AlInGaP	Yellow Green		
PDC52-CxDY04		Yellow		
PDC52-CxDA11		Amber		
PDC52-CxDR02		Orange-Red		
PDC52-CxDR11		Red		
PDC52-CxDR21		Deep Red		

Absolute Maximum Ratings at Ta=25°C

Parameter	Symbol	Rating		Unit
		G17/Y04/A11/R02/R11/R21	G05	
Power Dissipation per Dice	PAD	70	114	mW
Derating Liner from 25°C per Dice	--	0.33	0.4	mA/°C
Continuous Forward Current Per Dice	IAF	25	30	mA
Peak Current Per Dice (duty cycle 1/10, 1KHz)	IPF	90	100	mA
Reverse Voltage Per Dice	VR	5	5	V
Electrostatic Discharge (HBM)	ESD	/	1000	V
Operating Temperature	Topr	-35~+85#		°C
Storage Temperature	Tstg	-35~+85#		°C

Solder Conditions: 1/16 inch below seating plane for 3 -5 seconds at 260°C.

Electrical and Optical Characteristics at Ta=25°C

Parameter	Symbol	Chip	Min.	Typ.	Max.	Unit	Condition
Forward Voltage Per Segment	VF	G05	--	3.2	3.8	V	IF=20mA
		G17/Y04/A11/R02/R11/R21	--	2	2.8		
Luminous Intensity Per Segment	Iv	G05	--	218	--	mcd	IF=10mA
		G17	--	10	--		
		Y04	--	43	--		
		A11	--	59	--		
		R02	--	30	--		
		R11	--	20	--		
		R21	--	15	--		
Peak Emission Wavelength / Dominant Wavelength	$\lambda P/\lambda d$	G05	--	*/525	--	nm	IF=20mA
		G17	--	572/570	--		
		Y04	--	592/590	--		
		A11	--	612/605	--		
		R02	--	632/625	--		
		R11	--	644/630	--		
		R21	--	660/645	--		
Reverse Current	IR		--	--	100	μ A	VR=5V
Luminous Intensity Matching Ratio	Iv-m		--	--	2:1	--	IF=10mA

Typical Electrical/Optical Characteristic Curves

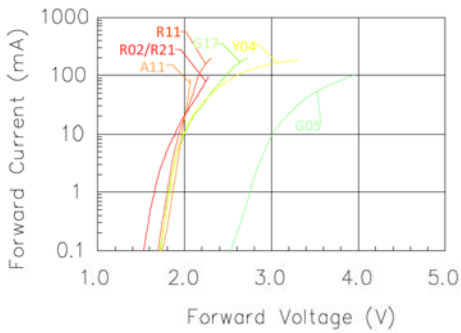

Fig 1. Forward Current vs. Forward Voltage

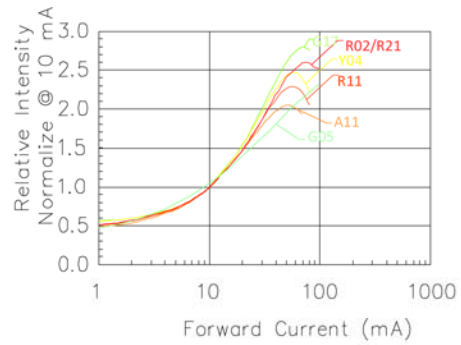

Fig 2. Relative Intensity vs. Forward Current

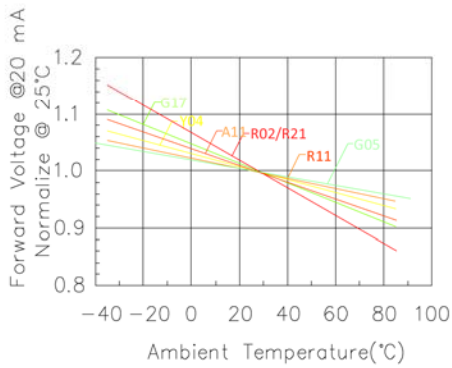

Fig 3. Forward Voltage vs. Temperature

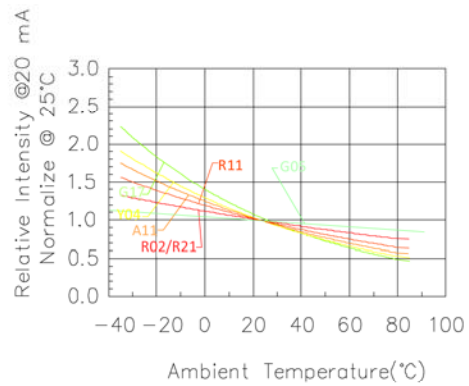

Fig 4. Relative Intensity vs. Temperature

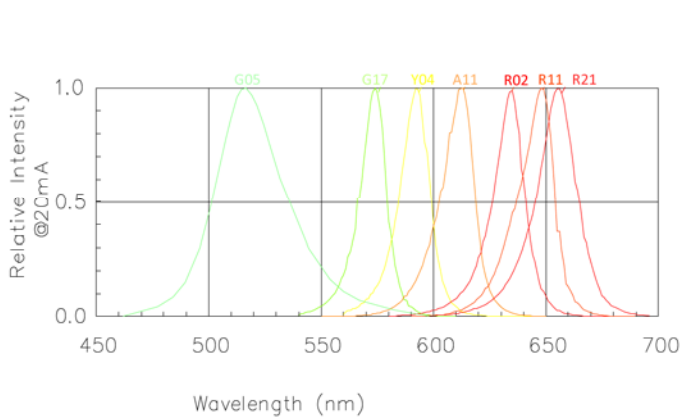

Fig 5. Relative Intensity vs. Wavelength

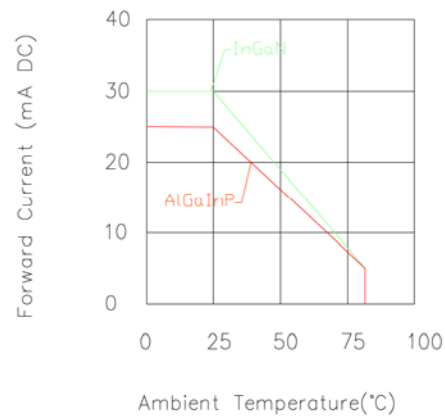

Fig 3. Forward Current vs. Ambient Temperature



Luminous General I_v Bin Grade (IF = 10mA)

Color Rank Limits (IF=20mA)

Remark: Unit=mcd

*Tolerance: ±20%

Remark: Unit=nm

*Tolerance: ±1

● Pure Green(G05)

Q	R	S
112.889	180.623	288.997
I	I	I
180.622	288.996	462.396

1	2	3	4	5
515.0	518.0	520.0	522.0	524.0
I	I	I	I	I
518.0	520.0	522.0	524.0	527.0

● Yellow Green(G17)

H	J	K
4.204	6.727	10.764
I	I	I
6.726	10.763	17.223

0	1	2	3	4
567.5	569.5	570.5	571.5	573.0
I	I	I	I	I
569.5	570.5	571.5	573.0	575.0

● Yellow (Y04)

L	M	N
17.224	27.559	44.096
I	I	I
27.558	44.095	70.554

1	2	3	4	5
583.0	585.0	587.0	589.0	591.0
I	I	I	I	I
585.0	587.0	589.0	591.0	593.0

● Amber (A11)

M	N	P
27.559	44.096	70.555
I	I	I
44.095	70.554	112.888

● Orange (R02)

L	M	N
17.224	27.559	44.096
I	I	I
27.558	44.095	70.554

● Red (R11)

K	L	M
10.764	17.224	27.559
I	I	I
17.223	27.558	44.095

● Deep Red(R21)

J	K	L
6.727	10.764	17.224
I	I	I
10.763	17.223	27.558

All Light-On Segments Feature & Pad Position

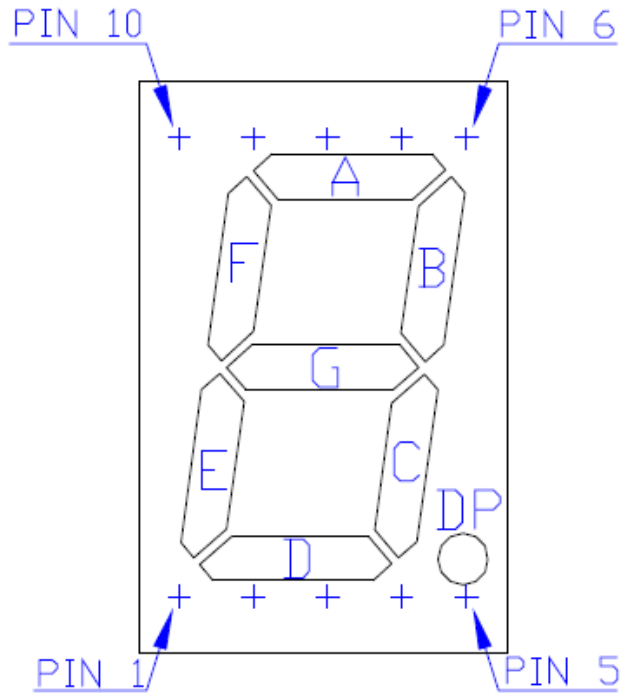

Internal Circuit Diagram

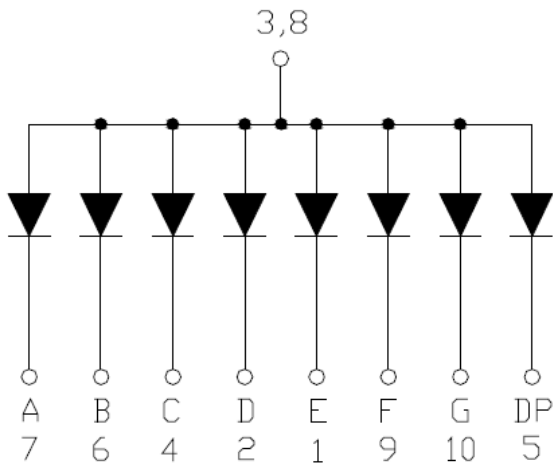

Common Anode

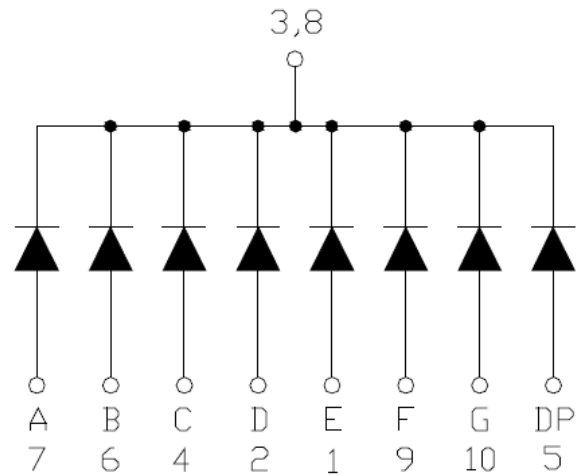

Common Cathode

Precautions for Use

1. Recommended soldering conditions

1.1. Wave soldering

Basic SPEC is ≤ 5 sec. When 260°C . If temperature is higher, time should be shorter ($+10^{\circ}\text{C} \rightarrow -1$ sec.).

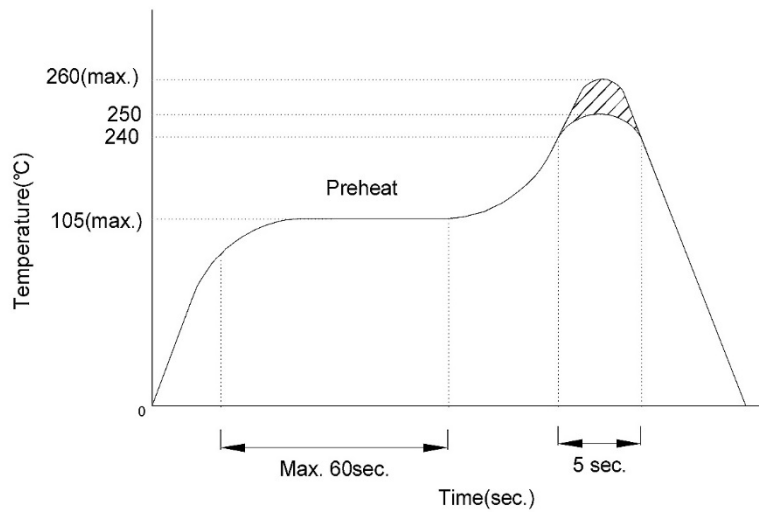

1.2. Soldering Iron:

Power dissipation of iron should be smaller than 15W and temp should be controllable. Soldering temperature should be under 260°C , time ≤ 3 sec.

Packing Dimensions

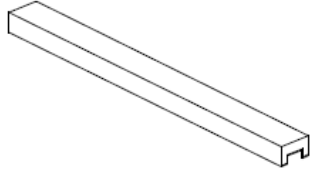

40 PCS Per Tube
Tube Size:
L520*W23*H21 mm

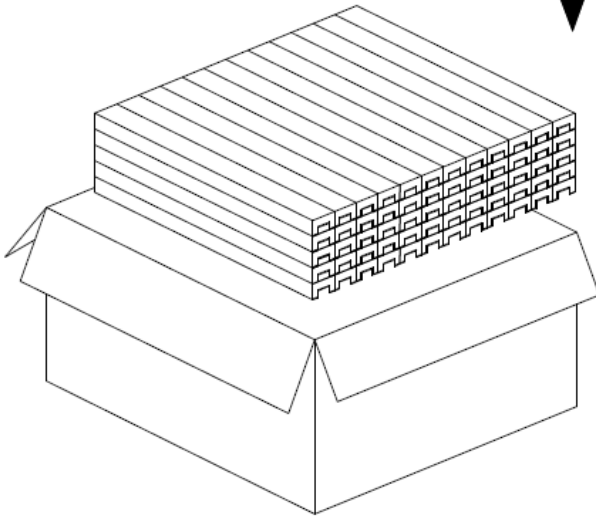

60 Tubes Per Inner Box
Total Q'TY: 2400 Pcs
Box Size:
L530*W265*H155 mm

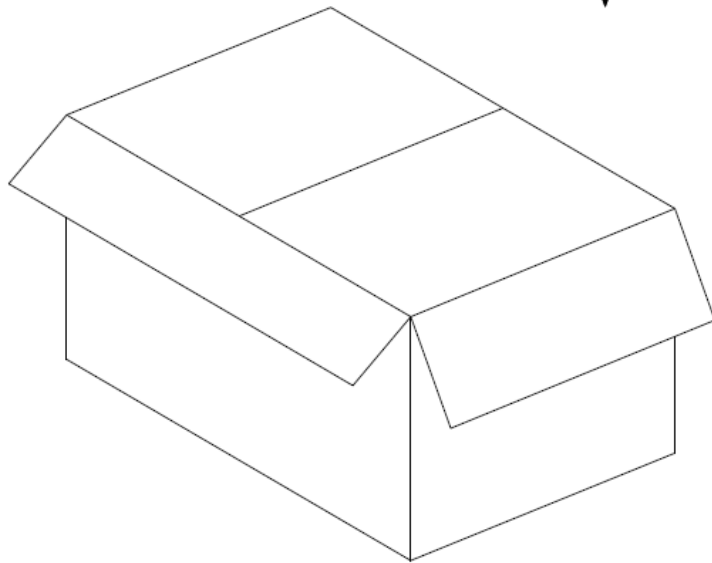

2 Inner Boxes Per Carton.
Total Q'TY: 4800 Pcs
Box Size:
L530*W345*H290 mm

Note: 1. Specifications subject to change without notice.



Customer Approval Signatures	Approved By	Checked By	Prepared By

Record Of Revisions			
Rev.	Comments	Page	Date
0	Released Spec	--	11/14/13
1	Logo Update	All	04/07/15