

PRODUCT SPECIFICATION

Part Number
PDC562A-CxDxxx

Details

- 0.56”(14.2mm) Display
- 2 Digit, 7 Segment
- Common Anode or Cathode
- AlInGaP or InGaN dice used

Features

- Low power consumption
- RoHS Compliant
- Gray Face, White Segments or Black Face, White Segments
- Easy mounting on PCB or socket

Mechanical Dimensions

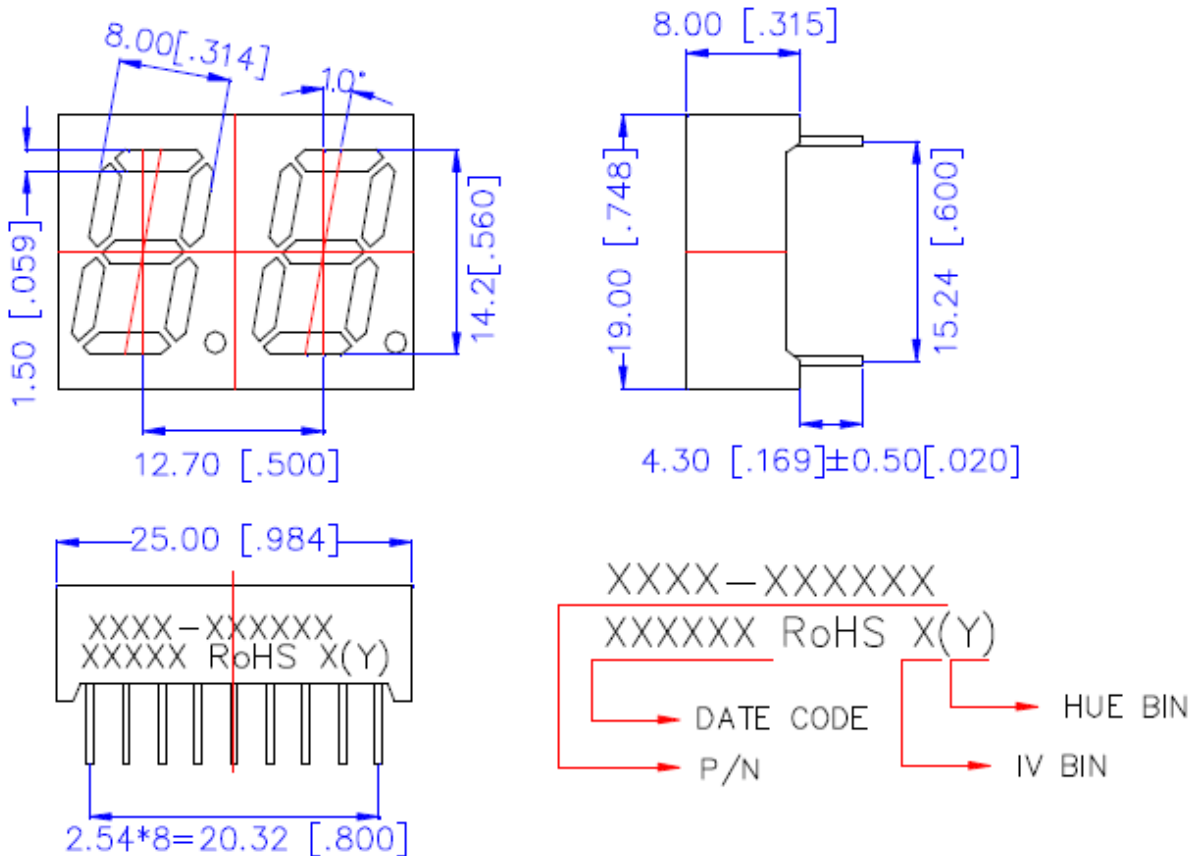

Notes:

1. Dimensions in millimeters [inch], and tolerance is ± 0.25 [.010] and angle is $\pm 1^\circ$ unless otherwise noted.
2. Bending \leq Length*1%
3. All pins are $\varnothing 0.51$ [.020] ± 0.1 [.004]
4. Specifications subject to change without notice



Device Selection Guide

Model Number	Chip		Description	Note
	Material	Emitting Color		
PDC562A-CxDG05	InGaN	True Green	Common Cathode x=C / Common Anode x=A	Add "BFWS" to end of part number for Black Face, White Segment version
PDC562A-CxDG17	AlInGaP	Yellow Green		
PDC562A-CxDY04		Yellow		
PDC562A-CxDA11		Amber		
PDC562A-CxDR02		Orange-Red		
PDC562A-CxDR11		Red		
PDC562A-CxDR21		Deep Red		

Absolute Maximum Ratings at Ta=25°C

Parameter	Symbol	Rating		Unit
		G17/Y04/A11/R02/R11/R21	G05	
Power Dissipation per Dice	PAD	70	114	mW
Derating Liner from 25°C per Dice	--	0.33	0.4	mA/°C
Continuous Forward Current Per Dice	IAF	25	30	mA
Peak Current Per Dice (duty cycle 1/10, 1KHz)	IPF	90	100	mA
Reverse Voltage Per Dice	VR	5	5	V
Electrostatic Discharge (HBM)	ESD	/	1000	V
Operating Temperature	Topr	-35~+85		°C
Storage Temperature	Tstg	-35~+85		°C

Solder Conditions: 1/16 inch below seating plane for 3 -5 seconds at 260°C.



Electrical and Optical Characteristics at Ta=25°C

Parameter	Symbol	Chip	Min.	Typ.	Max.	Unit	Condition
Forward Voltage Per Segment	VF	G05	--	3.2	3.8	V	IF=20mA
		G17/Y04/A11/R02/R11/R21	--	2	2.8		
Luminous Intensity Per Segment	Iv	G05	--	220	--	mcd	IF=10mA
		G17	--	12	--		
		Y04	--	50	--		
		A11	--	68	--		
		R02	--	32	--		
		R11	--	24	--		
		R21	--	18	--		
Peak Emission Wavelength / Dominant Wavelength	$\lambda P/\lambda d$	G05	--	*525	--	nm	IF=20mA
		G17	--	572/570	--		
		Y04	--	592/590	--		
		A11	--	612/605	--		
		R02	--	632/625	--		
		R11	--	644/630	--		
		R21	--	660/645	--		
Reverse Current	IR		--	--	100	μ A	VR=5V
Luminous Intensity Matching Ratio	Iv-m		--	--	2:1	--	IF=10mA

Typical Electrical/Optical Characteristic Curves

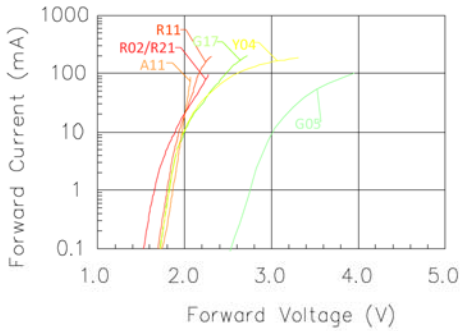

Fig 1. Forward Current vs. Forward Voltage

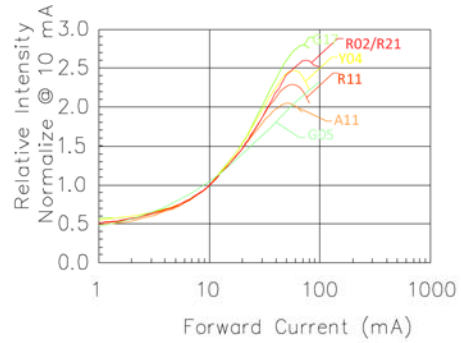

Fig 2. Relative Intensity vs. Forward Current

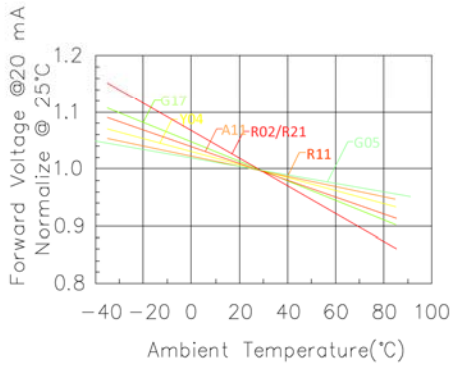

Fig 3. Forward Voltage vs. Temperature

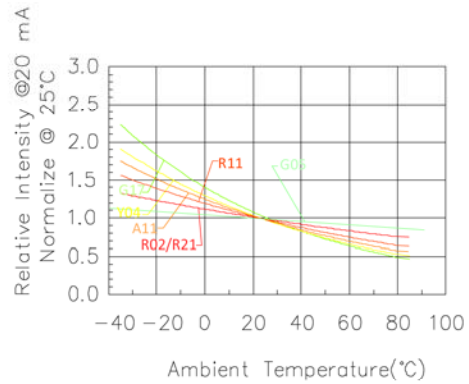

Fig 4. Relative Intensity vs. Temperature

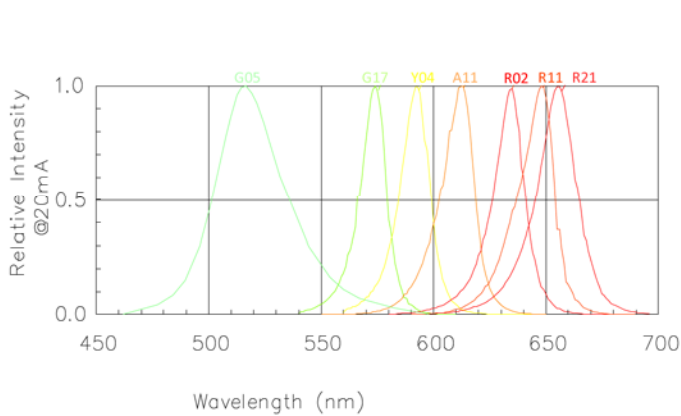

Fig 5. Relative Intensity vs. Wavelength

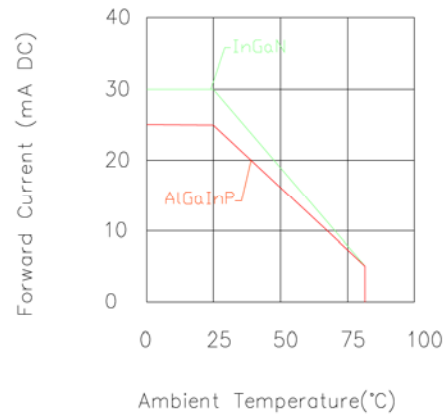

Fig 3. Forward Current vs. Ambient Temperature



Luminous General lv Bin Grade (IF = 10mA)

Color Rank Limits (IF=20mA)

Remark: Unit=mcd

*Tolerance: ±20%

Remark: Unit=nm

*Tolerance: ±1

● Pure Green(G05)

Q	R	S
<u>112.889</u>	<u>180.623</u>	<u>288.997</u>
I	I	I
<u>180.622</u>	<u>288.996</u>	<u>462.396</u>

1	2	3	4	5
<u>515.0</u>	<u>517.0</u>	<u>519.0</u>	<u>521.0</u>	<u>523.0</u>
I	I	I	I	I
<u>517.0</u>	<u>519.0</u>	<u>521.0</u>	<u>523.0</u>	<u>525.0</u>

● Yellow Green(G17)

H	J	K
<u>4.204</u>	<u>6.727</u>	<u>10.764</u>
I	I	I
<u>6.726</u>	<u>10.763</u>	<u>17.223</u>

0	1	2	3	4
<u>567.5</u>	<u>569.5</u>	<u>570.5</u>	<u>571.5</u>	<u>573.0</u>
I	I	I	I	I
<u>569.4</u>	<u>570.4</u>	<u>571.4</u>	<u>572.9</u>	<u>575.0</u>

● Yellow (Y04)

L	M	N
<u>17.224</u>	<u>27.559</u>	<u>44.096</u>
I	I	I
<u>27.558</u>	<u>44.095</u>	<u>70.554</u>

1	2	3	4	5
<u>583.0</u>	<u>585.0</u>	<u>587.0</u>	<u>589.0</u>	<u>591.0</u>
I	I	I	I	I
<u>585.0</u>	<u>587.0</u>	<u>589.0</u>	<u>591.0</u>	<u>593.0</u>

● Amber (A11)

M	N	P
<u>27.559</u>	<u>44.096</u>	<u>70.555</u>
I	I	I
<u>44.095</u>	<u>70.554</u>	<u>112.888</u>

● Orange (R02)

K	L	M
<u>10.764</u>	<u>17.224</u>	<u>27.559</u>
I	I	I
<u>17.223</u>	<u>27.558</u>	<u>44.095</u>

● Red (R11)

K	L	M
<u>10.764</u>	<u>17.224</u>	<u>27.559</u>
I	I	I
<u>17.223</u>	<u>27.558</u>	<u>44.095</u>

● Deep Red(R21)

J	K	L
<u>6.727</u>	<u>10.764</u>	<u>17.224</u>
I	I	I
<u>10.763</u>	<u>17.223</u>	<u>27.558</u>

All Light-On Segments Feature & Pad Position

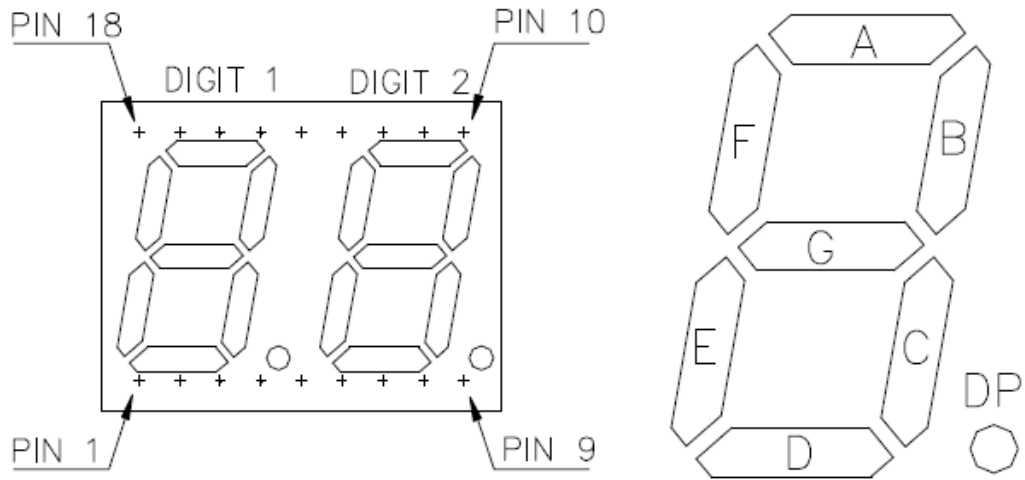

Internal Circuit Diagram

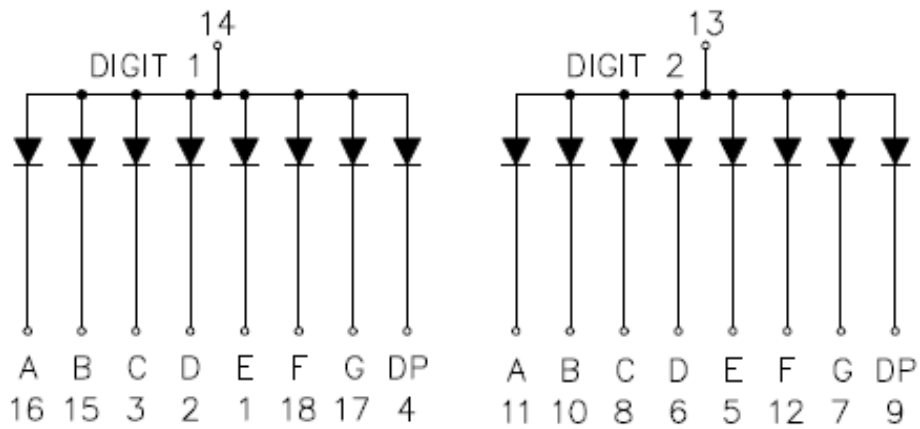

Common Anode

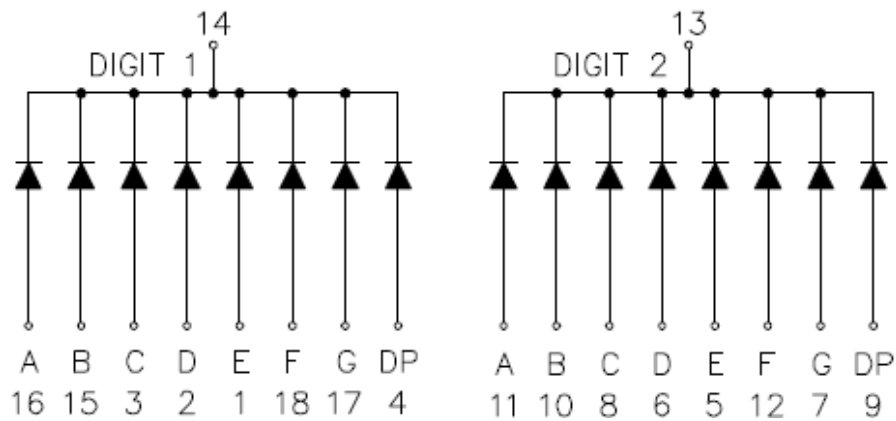

Common Cathode

Precautions for Use

1. Recommended soldering conditions

1.1. Wave soldering

Basic SPEC is ≤ 5 sec. When 260°C . If temperature is higher, time should be shorter ($+10^{\circ}\text{C} \rightarrow -1$ sec.).

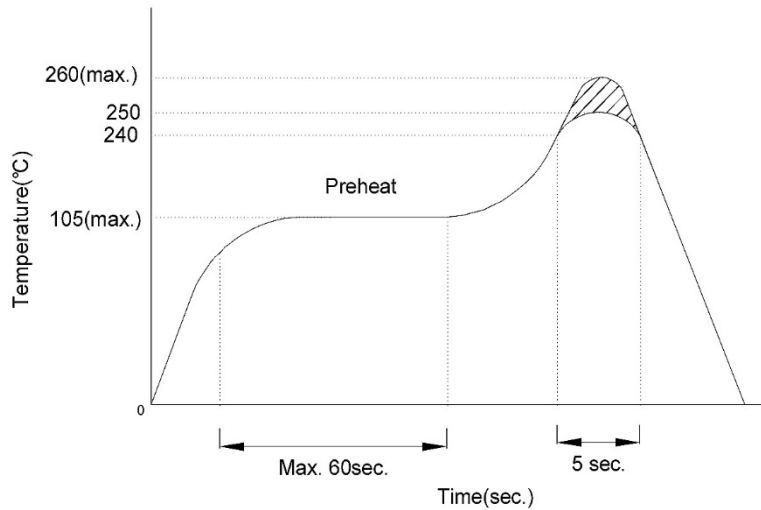

1.2. Soldering Iron:

Power dissipation of iron should be smaller than 15W and temp should be controllable. Soldering temperature should be under 260°C , time ≤ 3 sec.

Packing Dimensions

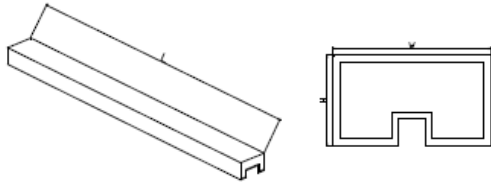

1 Tube From Box = 19PCS

Tube SIZE:
L520XW23XH21mm

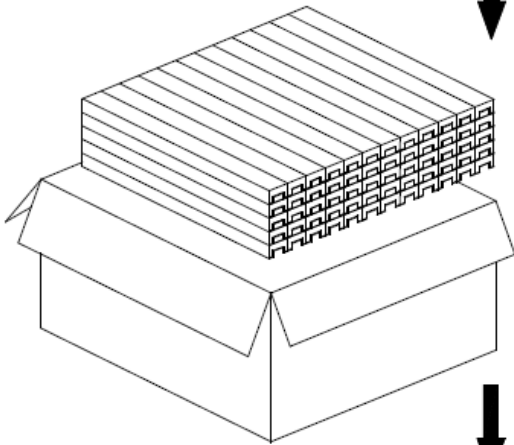

70 Tubes Per Inner Box
Q'TY 1330 PCS

Box SIZE:
L530 X W265 X H155mm

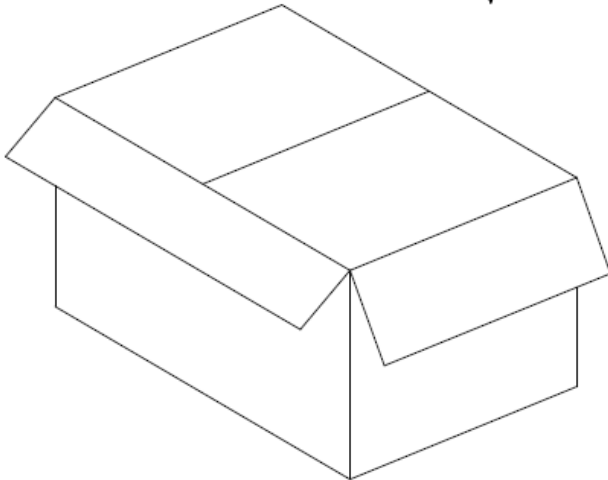

2 Boxes Per Carton
TOTAL Q'TY 2660 PCS

Carton SIZE:
L540 X W345 X H290mm

Note: 1. Specifications subject to change without notice.



Customer Approval Signatures	Approved By	Checked By	Prepared By

Record Of Revisions

Rev.	Comments	Page	Date
0	Released Spec	--	11/12/13
1	Logo Update	All	04/08/15