

PRODUCT SPECIFICATION

Part Number
PDC56SM-CxDxxx

Details

- .56" (14.2mm) Surface Mount LED Display
- 1 Digit, 7 Segment
- Common Anode or Cathode
- AlInGaP or InGaN dice used

Features

- Low power consumption
- RoHS Compliant
- Gray Face, White Segments or Black Face, White Segments
- Easy mounting on PCB or socket

Mechanical Dimensions

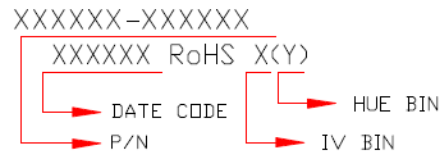
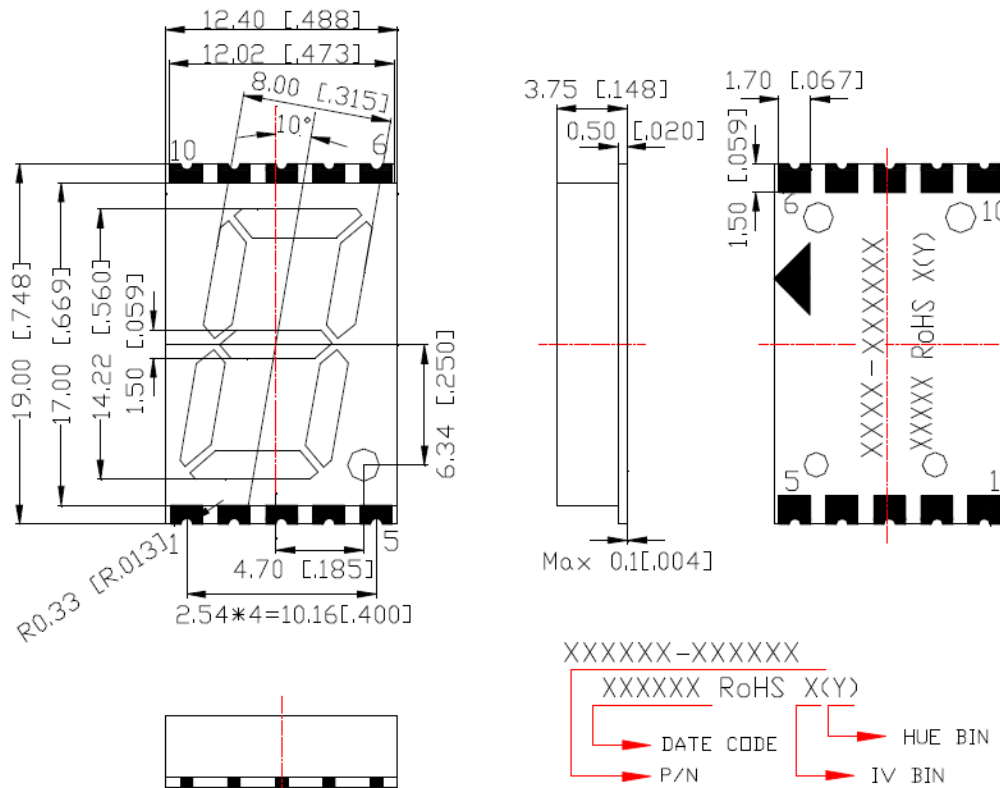

Notes:

1. Dimensions in millimeters [inch], and tolerance is ± 0.25 [0.010] and angle is $\pm 1^\circ$ unless otherwise noted.
2. Bending \leq Length*1%
3. All pins are 0.50 by 0.30
4. Specifications subject to change without notice



Device Selection Guide

Model Number	Chip		Description	Note
	Material	Emitting Color		
PDC56SM-CxDG05	InGaN	True Green	Common Cathode x=C / Common Anode x=A	Add "BFWS" to end of part number for Black Face, White Segment version
PDC56SM-CxDG17	AlInGaP	Yellow Green		
PDC56SM-CxDY04		Yellow		
PDC56SM-CxDA11		Amber		
PDC56SM-CxDR02		Orange-Red		
PDC56SM-CxDR11		Red		
PDC56SM-CxDR21		Deep Red		

Absolute Maximum Ratings at Ta=25°C

Parameter	Symbol	Rating		Unit
		G17/Y04/A11/R02/R11/R21	G05	
Power Dissipation per Dice	P _{AD}	70	114	mW
Derating Liner from 25°C per Dice	--	0.33	0.4	mA/°C
Continuous Forward Current Per Dice	I _{AF}	25	30	mA
Peak Current Per Dice (duty cycle 1/10, 1KHz)	I _{PF}	90	100	mA
Reverse Voltage Per Dice	V _R	5	5	V
Electrostatic Discharge (HBM)	ESD	/	1000	V
Operating Temperature	T _{opr}	-40~+105		°C
Storage Temperature	T _{stg}	-40~+105		°C

Electrical and Optical Characteristics at Ta=25°C

Parameter	Symbol	Chip	Min.	Typ.	Max.	Unit	Condition
Forward Voltage Per Segment	VF	G05	--	3.2	3.8	V	IF=20mA
		G17/Y04/A11/ R02/R11/R21	--	2	2.8		
Luminous Intensity Per Segment	Iv	G05	--	70	--	mcd	IF=10mA
		G17	--	3	--		
		Y04	--	17	--		
		A11	--	18	--		
		R02	--	8	--		
		R11	--	9	--		
		R21	--	6	--		
Peak Emission Wavelength / Dominant Wavelength	$\lambda P/\lambda d$	G05	--	*525	--	nm	IF=20mA
		G17	--	572/570	--		
		Y04	--	592/590	--		
		A11	--	612/605	--		
		R02	--	632/625	--		
		R11	--	644/630	--		
		R21	--	660/645	--		
Reverse Current	IR		--	--	100	μA	VR=5V
Luminous Intensity Matching Ratio	Iv-m		--	--	2:1	--	IF=10mA

Typical Electrical/Optical Characteristic Curves

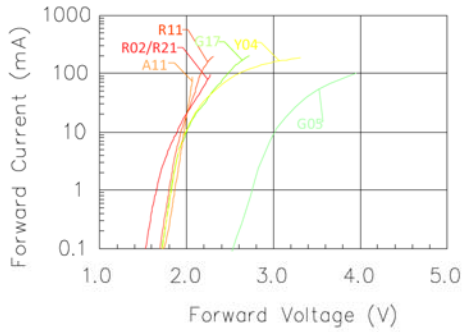

Fig 1. Forward Current vs. Forward Voltage

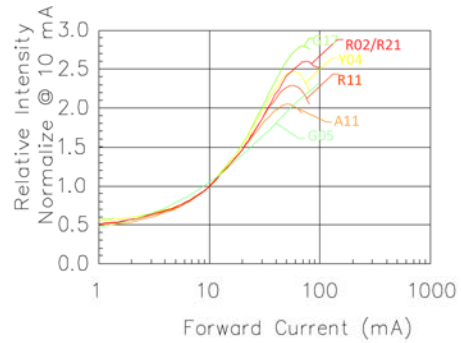

Fig 2. Relative Intensity vs. Forward Current

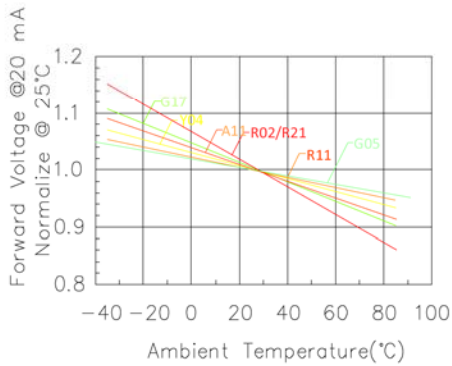

Fig 3. Forward Voltage vs. Temperature

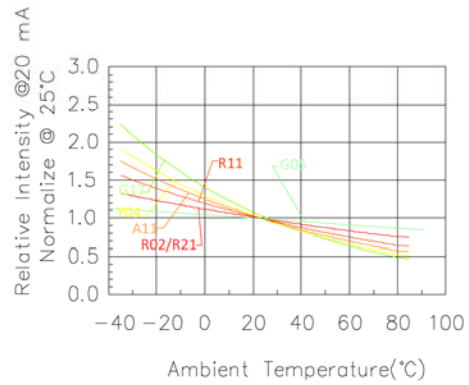

Fig 4. Relative Intensity vs. Temperature

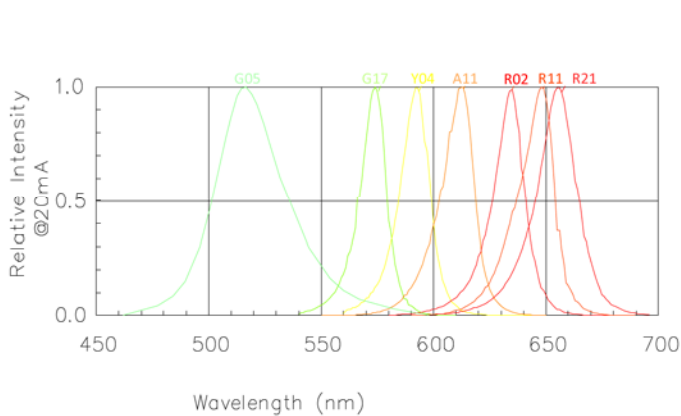

Fig 5. Relative Intensity vs. Wavelength

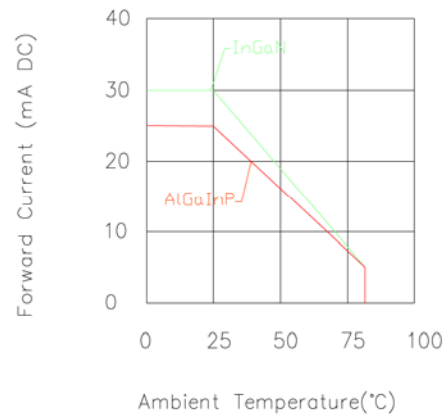

Fig 3. Forward Current vs. Ambient Temperature

Luminous General lv Bin Grade (IF = 10mA)
Color Rank Limits (IF=20mA)

Remark: Unit=mcd

*Tolerance: ±20%

Remark: Unit=nm

*Tolerance: ±1

● Pure Green(G05)

M	N	P
27.559	44.096	70.555
I	I	I
44.095	70.554	112.888

1	2	3	4	5
515.0	517.0	519.0	521.0	523.0
I	I	I	I	I
517.0	519.0	521.0	523.0	525.0

● Yellow Green(G17)

F	G	H
1.641	2.627	4.204
I	I	I
2.626	4.203	6.726

0	1	2	3	4
567.5	569.5	570.5	571.5	573.0
I	I	I	I	I
569.4	570.4	571.4	572.9	575.0

● Yellow (Y04)

J	K	L
6.727	10.764	17.224
I	I	I
10.763	17.223	27.558

1	2	3	4	5
583.0	585.0	587.0	589.0	591.0
I	I	I	I	I
585.0	587.0	589.0	591.0	593.0

● Amber (A11)

K	L	M
10.764	17.224	27.559
I	I	I
17.223	27.558	44.095

● Orange (R02)

H	J	K
4.204	6.727	10.764
I	I	I
6.726	10.763	17.223

● Red (R11)

H	J	K
4.204	6.727	10.764
I	I	I
6.726	10.763	17.223

● Deep Red (R21)

G	H	J
2.627	4.204	6.727
I	I	I
4.203	6.726	10.763

All Light-On Segments Feature & Pad Position

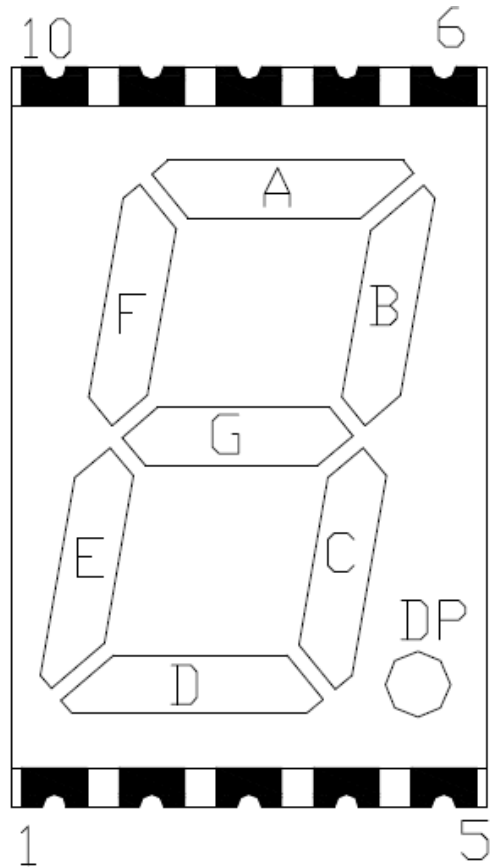

Internal Circuit Diagram

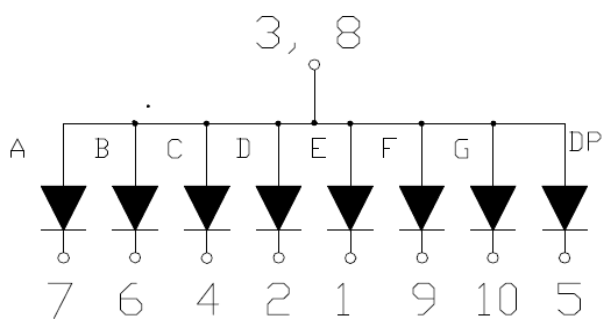

Common Anode

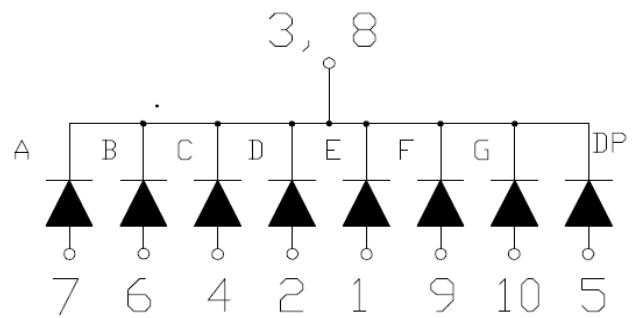

Common Cathode

Precautions for Use

1. Recommended soldering conditions

1.1. Wave soldering

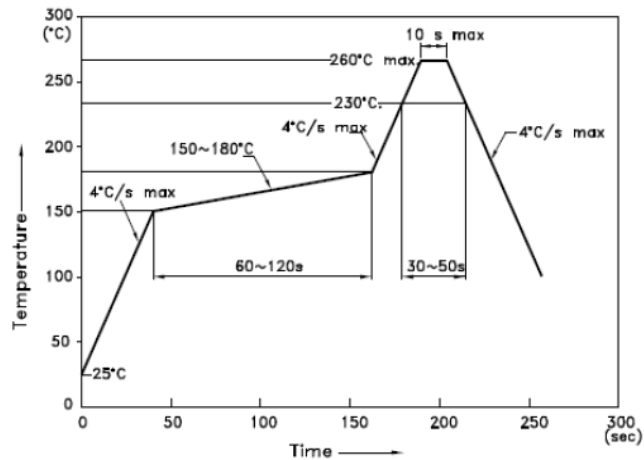

NOTES:

1. We recommend the reflow temperature 245°C(±5°C). The maximum soldering temperature should be limited to 260°C.
2. Don't cause stress to the epoxy resin while it is exposed to high temperature.
3. Number of reflow process shall be 2 times or less.

1.2. Recommended Soldering Pad:

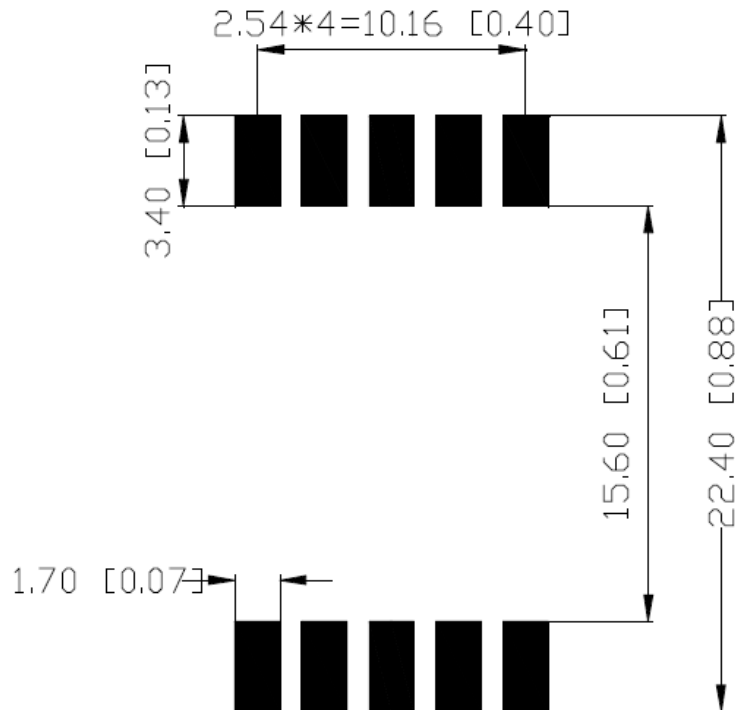

Reel Dimensions

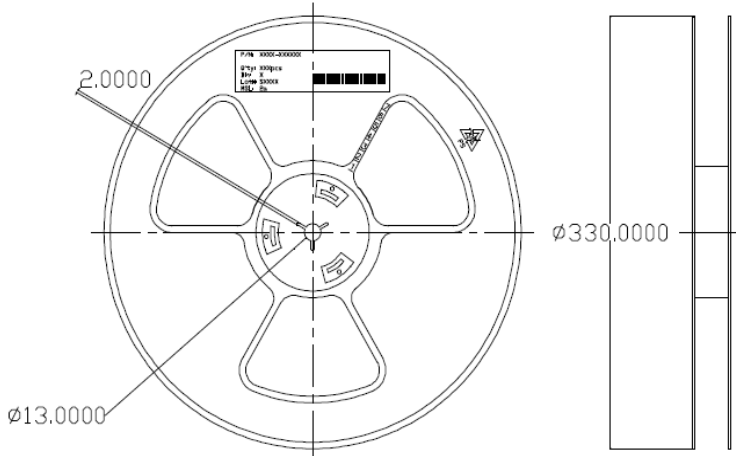

Packing Dimensions

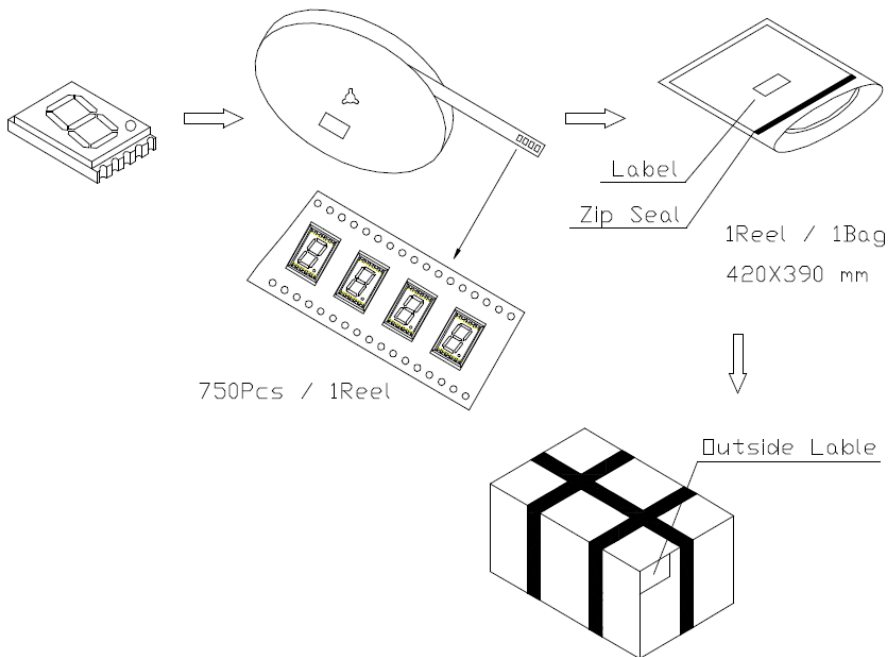

Note: 1. Specifications subject to change without notice.

