

PRODUCT SPECIFICATION

Part Number
PDC56SM-CxMRGB1

Details

- .56" (14.2mm) Single Digit SMD Display
- Common Anode and Common Cathode
- Emitting Color: Red, Green, Blue
- AlInGaP and InGaN dice used
- Gray Face, White Segment

Features

- Qualified according to JEDEC moisture sensitivity level 2A
- RoHS Compliant
- Low Power Consumption
- Easy mounting on PCB

Mechanical Dimensions

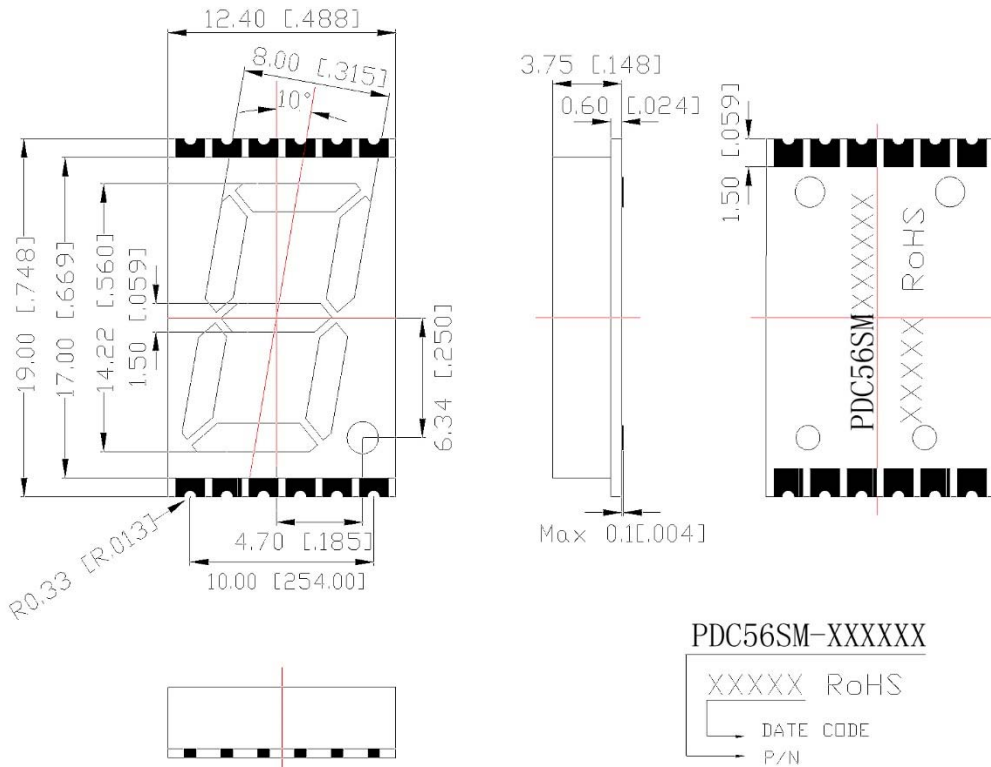

Notes:

1. Dimension in millimeter [inch], and tolerance is ± 0.25 [0.010] unless otherwise noted.
2. Bending \leq Length * 1%.
3. Specifications subject to change without notice





Device Selection Guide

Model Number		Chip	
Common Anode	Common Cathode	Material	Emitting Color
PDC56SM-CAMRGB1	PDC56SM-CCMRGB1	AllInGaP	Orange-Red
		InGaN	Green
		InGaN	Blue

Absolute Maximum Ratings at Ta=25 °C

Orange-Red			
Parameter	Symbol	Rating	Unit
Power Dissipation per Dice	P _{AD}	70	mW
Derating Liner from 25°C per Dice	--	0.33	mA/°C
Continuous Forward Current Per Dice	I _{AF}	25	mA
Peak Current Per Dice (duty cycle 1/10, 1KHz)	IPF	90	mA
Reverse Voltage Per Dice	VR	5	V
Operating Temperature	Topr	-40~+105	°C
Storage Temperature	Tstg	-40~+105	°C

Green			
Parameter	Symbol	Rating	Unit
Power Dissipation per Dice	P _{AD}	114	mW
Derating Liner from 25°C per Dice	--	0.4	mA/°C
Continuous Forward Current Per Dice	I _{AF}	30	mA
Peak Current Per Dice (duty cycle 1/10, 1KHz)	IPF	100	mA
Reverse Voltage Per Dice	VR	5	V
Electrostatic Discharge (HBM)	ESD	1000	V
Operating Temperature	Topr	-40~+105	°C
Storage Temperature	Tstg	-40~+105	°C

Blue			
Parameter	Symbol	Rating	Unit
Power Dissipation per Dice	P _{AD}	114	mW
Derating Liner from 25°C per Dice	--	0.4	mA/°C
Continuous Forward Current Per Dice	I _{AF}	30	mA
Peak Current Per Dice (duty cycle 1/10, 1KHz)	IPF	100	mA
Reverse Voltage Per Dice	VR	5	V
Electrostatic Discharge (HBM)	ESD	1000	V
Operating Temperature	Topr	-40~+105	°C
Storage Temperature	Tstg	-40~+105	°C



Electrical and Optical Characteristics at Ta=25 °C

Orange-Red						
Parameter	Symbol	Min.	Typ.	Max.	Unit	Condition
Forward Voltage Per Segment	VF	--	2	2.8	V	IF=20mA
Luminous Intensity Per Segment	Iv	--	8		mcd	IF=10mA
Peak Emission Wavelength	λP	--	632		nm	IF=20mA
Dominant Wavelength	Ld	--	625		nm	IF=20mA
Spectrum Radiation Bandwidth	Δλ	--	20		nm	IF=20mA
Reverse Current	IR	--	--	100	μA	VR=5V
Luminous Intensity Matching Ratio	Iv-m	--	--	2:1	--	IF=10mA

Green						
Parameter	Symbol	Min.	Typ.	Max.	Unit	Condition
Forward Voltage Per Segment	VF	--	3.2	3.8	V	IF=20mA
Luminous Intensity Per Segment	Iv	--	70		mcd	IF=10mA
Dominant Wavelength	ld	--	525		nm	IF=20mA
Spectrum Radiation Bandwidth	Δλ	--	30		nm	IF=20mA
Reverse Current	IR	--	--	100	μA	VR=5V
Luminous Intensity Matching Ratio	Iv-m	--	--	2:1	--	IF=10mA

Blue						
Parameter	Symbol	Min.	Typ.	Max.	Unit	Condition
Forward Voltage Per Segment	VF	--	3.2	3.8	V	IF=20mA
Luminous Intensity Per Segment	Iv	--	12		mcd	IF=10mA
Dominant Wavelength	ld	--	470		nm	IF=20mA
Spectrum Radiation Bandwidth	Δλ	--	30		nm	IF=20mA
Reverse Current	IR	--	--	100	μA	VR=5V
Luminous Intensity Matching Ratio	Iv-m	--	--	2:1	--	IF=10mA

All Light On Segments Feature & Pad Position

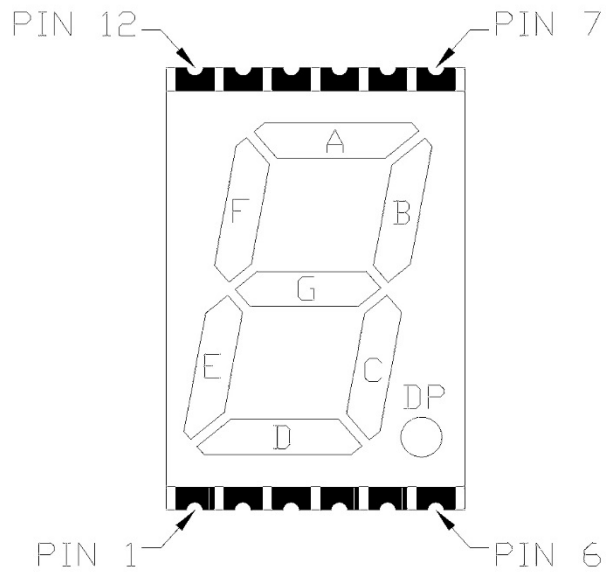

Internal Circuit Diagram

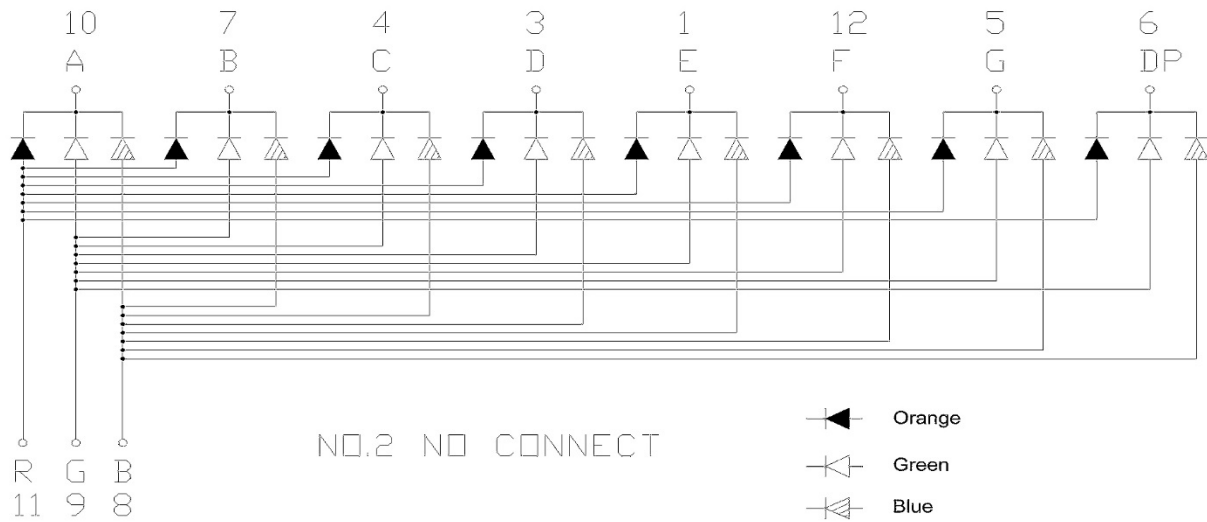

Typical Electrical / Optical Characteristic Curves

- **Orange-Red**

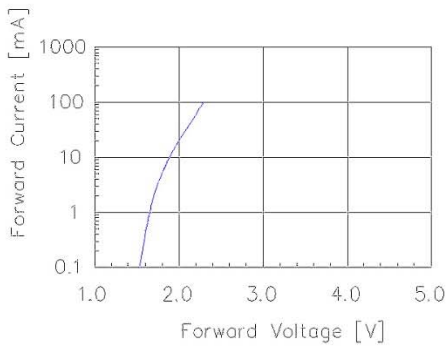

Fig 1. Forward Current vs. Forward Voltage

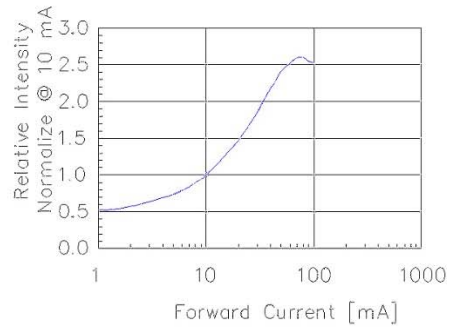

Fig 2. Relative Intensity vs. Forward Current

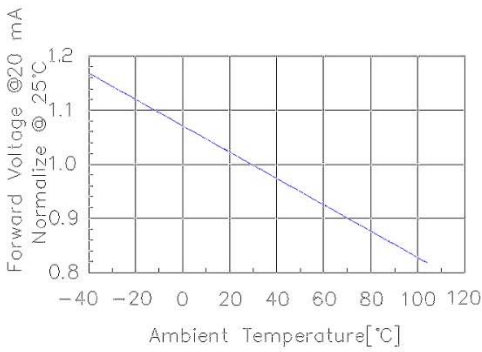

Fig 3. Forward Voltage vs. Temperature

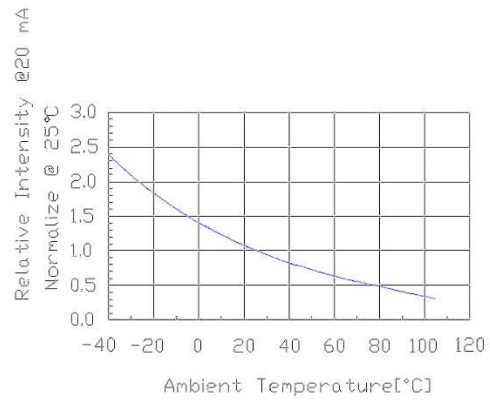
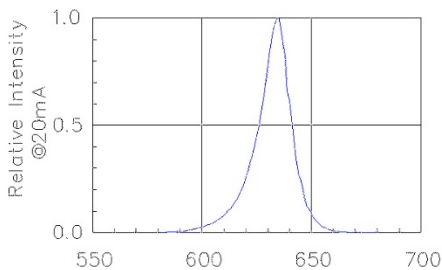

Fig 4. Relative Intensity vs. Temperature



Typical Electrical / Optical Characteristic Curves

- Green**

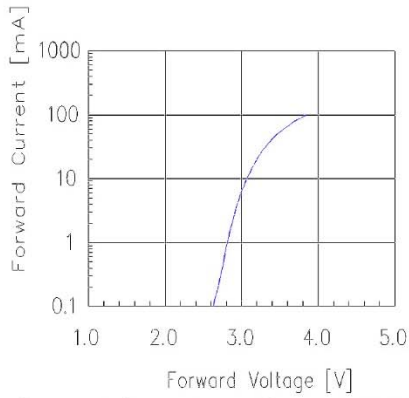

Fig 1. Forward Current vs. Forward Voltage

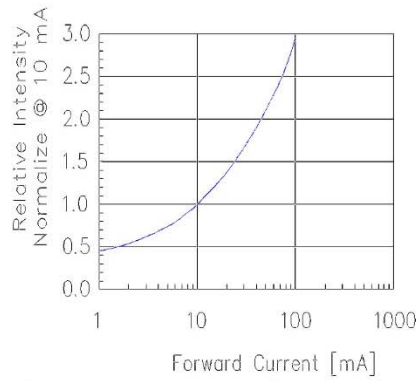

Fig 2. Relative Intensity vs. Forward Current

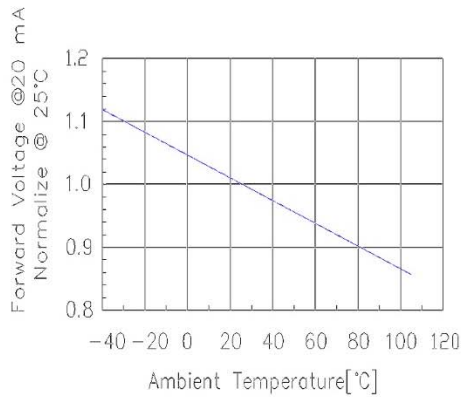

Fig 3. Forward Voltage vs. Temperature

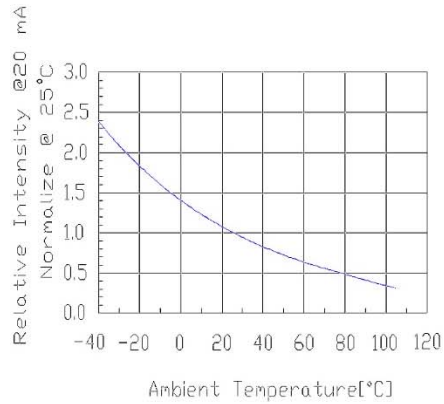

Fig 4. Relative Intensity vs. Temperature

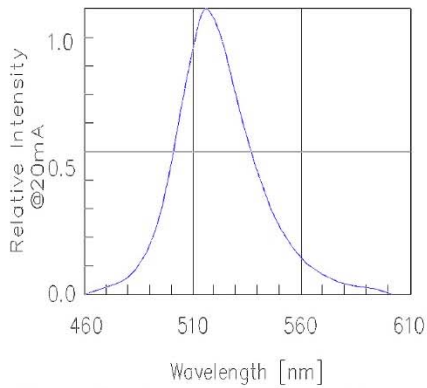

Fig 5. Relative Intensity vs. Wavelength

Typical Electrical / Optical Characteristic Curves

- **Blue**

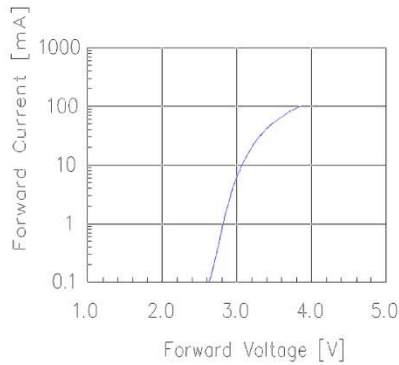

Fig 1. Forward Current vs. Forward Voltage

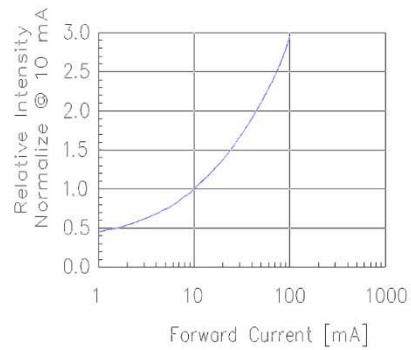

Fig 2. Relative Intensity vs. Forward Current

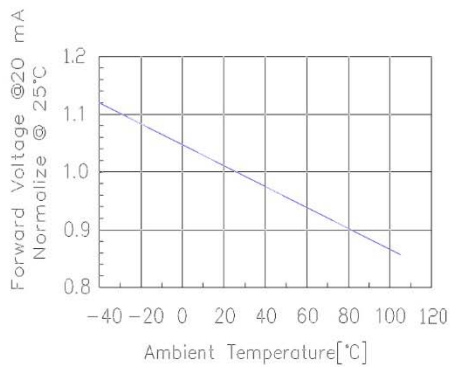

Fig 3. Forward Voltage vs. Temperature

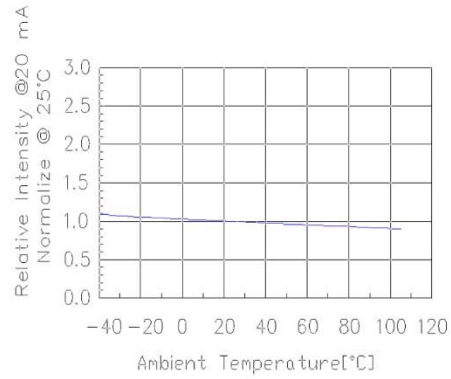

Fig 4. Relative Intensity vs. Temperature

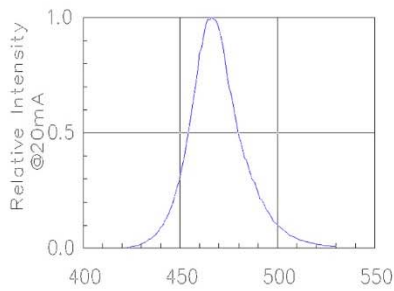
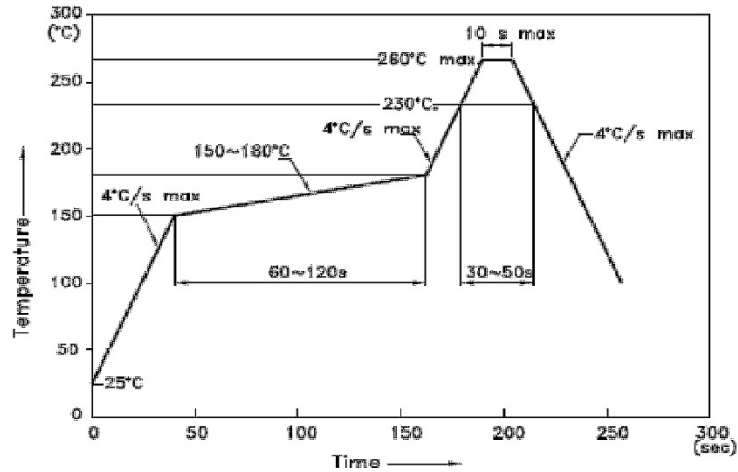

Fig 5. Relative Intensity vs. Wavelength

IR Reflow Temperature / Time



Notes:

1. We recommend reflow temp of 245°C (+/- 5°C) Maximum soldering temp should be limited to 260°C
2. Do not cause stress to the epoxy resin while it is exposed to high temperature
3. Number of reflow process shall be 2 times or less

Soldering Pad Size

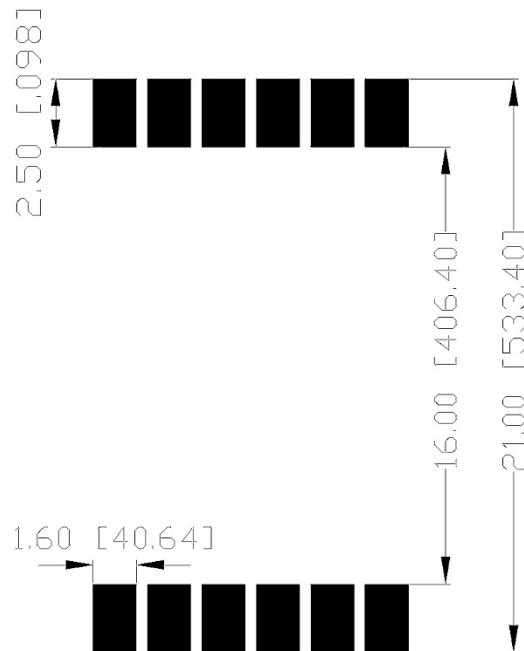

Reel Dimensions

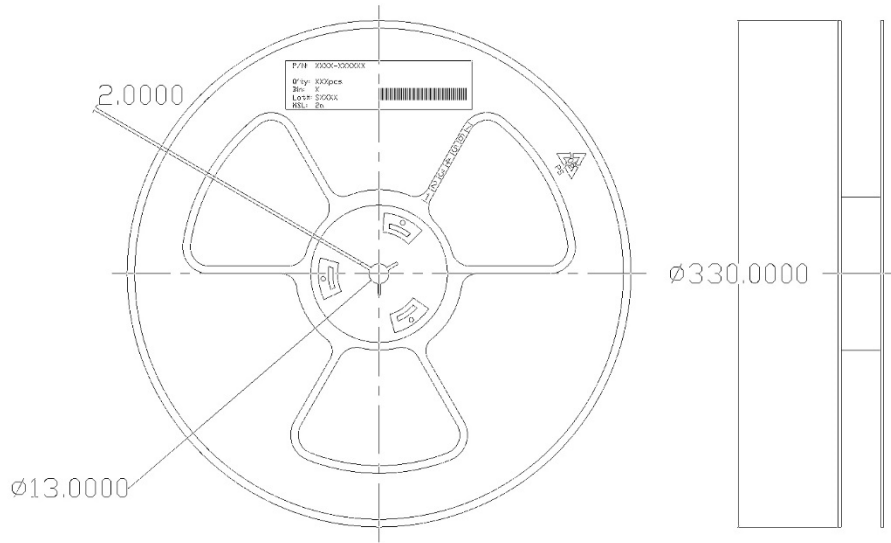

Packing and Label Specifications

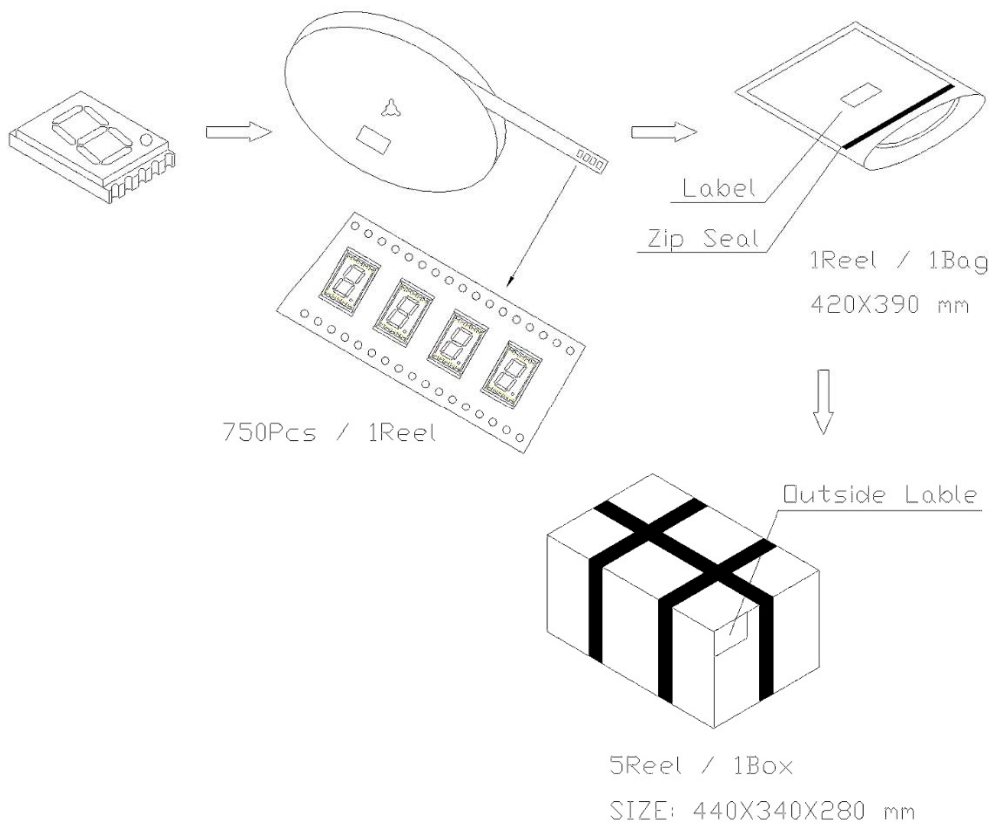



Customer Approval Signatures	Approved By	Checked By	Prepared By

Record Of Revisions			
Rev.	Comments	Page	Date
0	Released Spec	--	07/15/13