

PRODUCT SPECIFICATION

Part Number
PLC1515A-WCRGB1

Details

- Full Color SMD LED (Black Lead Frame)
- PLCC-4 1.5 x 1.5 x 1.0mm
- 4,000 piece reels
- Emitting Color: RGB
- AlInGaP and InGaN dice used

Features

- High luminous intensity
- Small package enables 2.5 pitch display
- Wide viewing angle 110°
- RoHS Compliant

Mechanical Dimensions

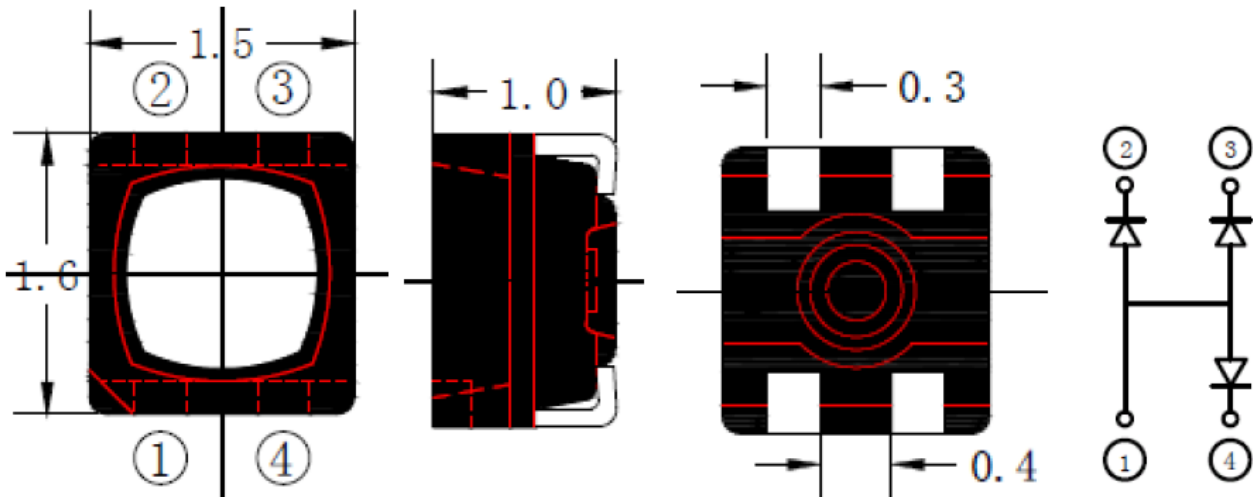

1	Common Anode
2	Cathode (Blue)
3	Cathode (Green)
4	Cathode (Red)

Notes:

1. Specifications subject to change without notice
2. Tolerance of measurement of dimension: $\pm 0.2\text{mm}$





Device Selection Guide

Model Number	Chip		Encapsulation
PLC1515A-WCRGB1	Material	Emitting Color	Level Matte
	AllInGaP	Red	
	InGaN	Green	
	InGaN	Blue	

Absolute Maximum Ratings at Ta=25 °C

Parameter	Symbol		Rating	Unit
Power Dissipation	Pd	R	72	mW
		G	91	
		B	96	
Forward Current (DC)	IF	R	30	mA
		G	30	
		B	30	
Peak Forward Current (1/10 Duty Cycle 0.1ms Pulse Width)	IFP	R	100	mA
		G	100	
		B	100	
Reverse Voltage	VR		5	V
Junction Temperature	Tj	R	125	°C
		G	125	
		B	125	
Operating Temperature	Topr		-40~+85	°C
Storage Temperature	Tstg		-40~+100	°C
Soldering Temperature	Tsol		Reflow Soldering: 260°C for 10 sec Hand Soldering: 350°C for 3 sec	

Note: Proper current rating must be observed to maintain junction temperature below the maximum at all times.

Electrical and Optical Characteristics at Ta=25 °C

Parameter	Symbol	Min.	Typ.	Max.	Unit	Condition
Forward Voltage	VF	R	--	2.0	--	V
		G	--	3.0	--	
		B	--	3.1	--	
Luminous Intensity	Iv	R	--	280	--	mcd
		G	--	600	--	
		B	--	150	--	
Peak Wavelength	λP	R	--	631	--	nm
		G	--	517	--	
		B	--	462	--	
Dominant Wavelength	λD	R	--	621	--	
		G	--	520	--	
		B	--	467	--	
Spectrum Radiation Bandwidth	Δλ	R	--	15	--	
		G	--	32	--	
		B	--	22	--	
Viewing Angle	2θ 1/2	R	--	110	--	deg
		G	--	110	--	
		B	--	110	--	
Reverse Current	IR	R	--	--	10	μA
		G	--	--	10	
		B	--	--	10	

Notes:

1. Pulse width ≤ 0.1 msec, duty $\leq 1/10$
2. Proper current rating must be observed to maintain junction temperature below the maximum at all the time.

Recommended Soldering Pad Pattern

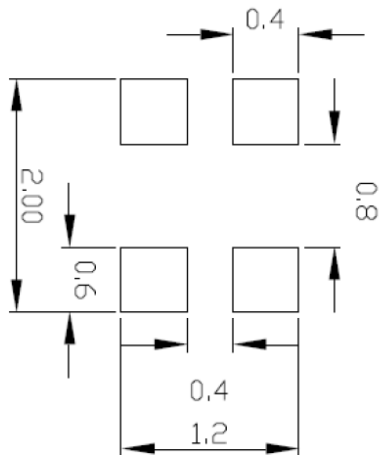

Luminous Intensity Rank Limits

Bin Code	Red		Unit
	Min	Max	
21	170	220	mcd
22	220	290	
23	290	380	

Bin Code	Green		Unit
	Min	Max	
24	380	490	mcd
25	490	640	
26	640	830	

Bin Code	Blue		Unit
	Min	Max	
19	77	130	mcd
20	130	170	
21	170	220	

Dominant Wavelength Rank Limits

Bin Code	Red		Unit
	Min	Max	
A5	615	620	nm
R1	620	625	
R2	625	630	

Bin Code	Green		Unit
	Min	Max	
TG1	515	520	nm
TG2	520	525	
TG3	525	530	

Bin Code	Blue		Unit
	Min	Max	
B5	460	465	nm
B6	465	470	
B7	470	475	

Forward Voltage Rank Limits

Bin Code	Red		Unit
	Min	Max	
V1C	1.8	2.1	Unit
V2A	2.1	2.4	

Bin Code	Green		Unit
	Min	Max	
V2C	2.7	3.0	V
V3A	3.0	3.3	

Bin Code	Blue		Unit
	Min	Max	
V2C	2.7	3.0	V
V3A	3.0	3.3	

Note: Tolerance of measurement of Forward Voltage $\pm 0.1V$

Typical Electrical / Optical Characteristic Curves

- (Ta = 25°C Unless Otherwise Noted)

Figure1. Forward Current VS. Forward Voltage

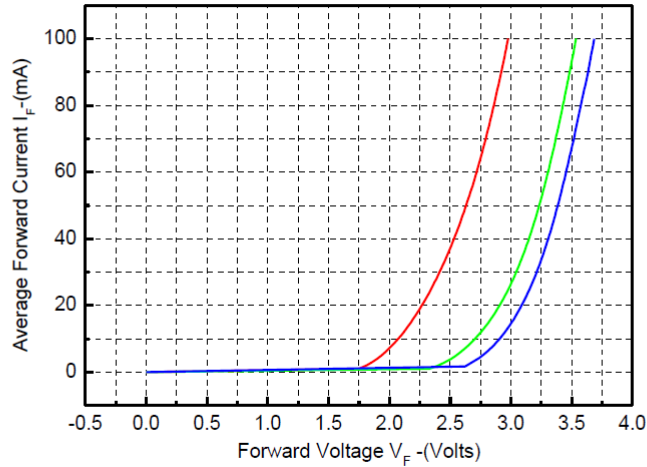

Figure2. Relative Spectral Power Distribution vs. Wavelength

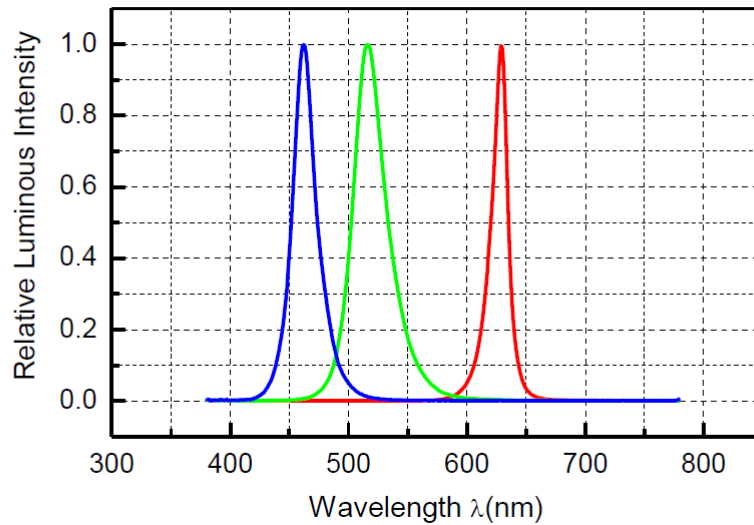
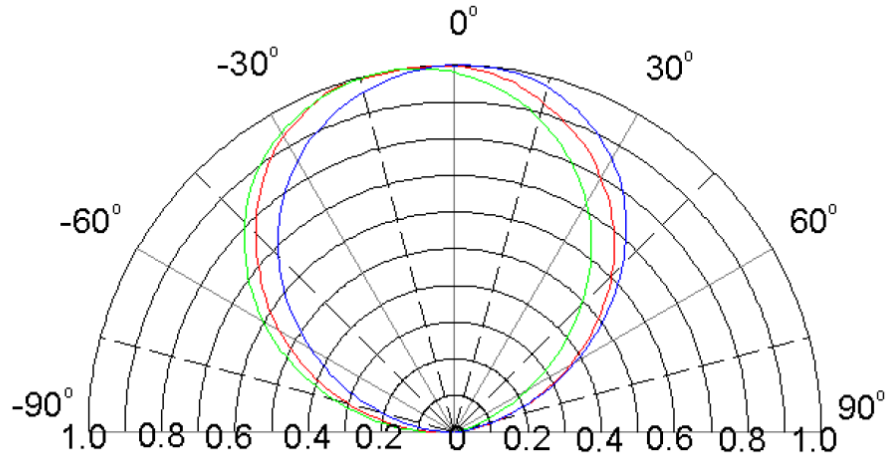
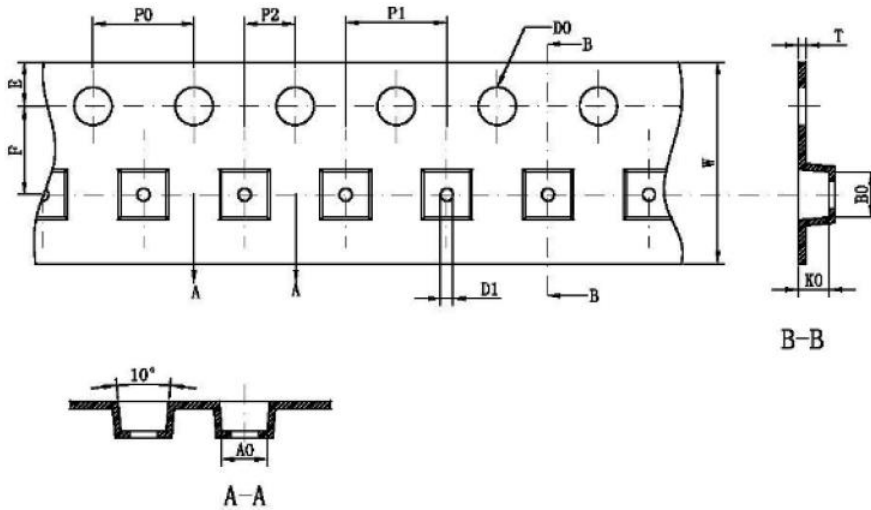

Figure3. Relative Luminosity VS. Radiation Angle



Package – Tape Dimensions



Unit: mm

符号	A0	B0	K0	P0	P1	P2
规格	1.8±0.1	1.85±0.1	1.20±0.1	4±0.1	4±0.1	2±0.1
符号	W	T	E	F	D0	D1
规格	8±0.3	0.25±0.05	1.75±0.1	3.5±0.1	∅1.5 ^{+0.1} ₀	∅0.5 ^{+0.1} ₀

Reel Dimensions

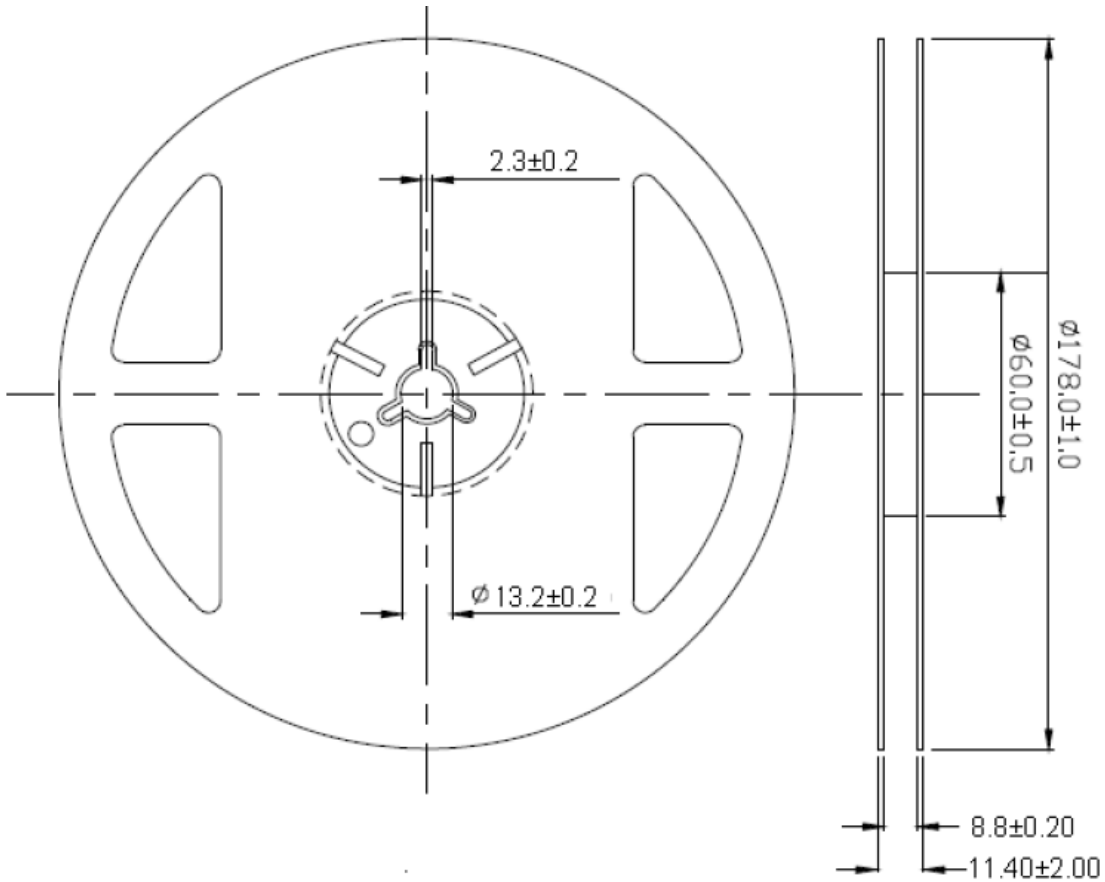

Notice: (1) Quantity:4000PCS/Reel
 (2)Tolerance unless mentioned is ± 0.2 mm

Packaging

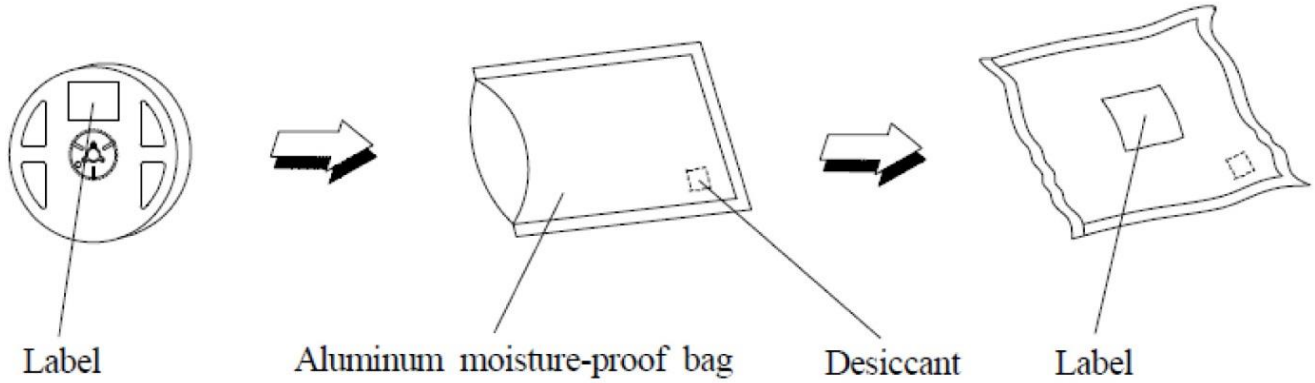

Package	Package Dimensions		Distribution of layer or box		Total		Note
	Size	Unit	Amount	Unit	Amount	Unit	
Reel	8	mm	1	Reel	4000	pcs	
Inner Box	265 x 235 x 78	mm	5	Reel	20000	pcs	
Outer Box	430 x 330 x 270	mm	4	Inner Box	80000	pcs	

Note: Specifications subject to change without notice

Soldering

- Hand Soldering

Soldering Temperature	350°C	One Time Only
Soldering Time	3 sec	

- Reflow Soldering

	Lead Solder	Lead-Free Solder
Pre-Heat	120~150°C	180~200°C
Pre-Heat Time	120 sec Max	120 Sec Max.
Peak	240°C Max	260°C Max
Temperature Soldering Time Condition	10 sec Max. refer to temp profile A	10 sec Max. refer to temp profile B (N2 reflow is recommended)

A. Lead Solder

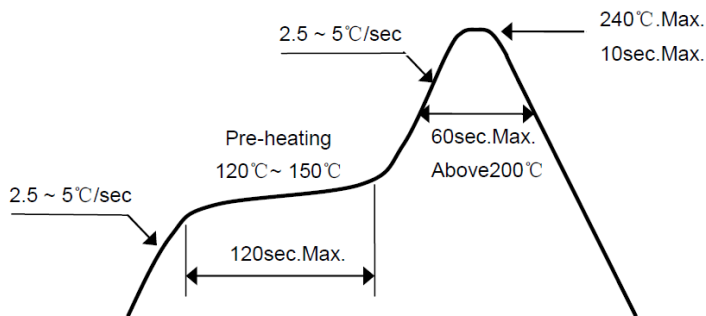

B. Lead-Free Solder

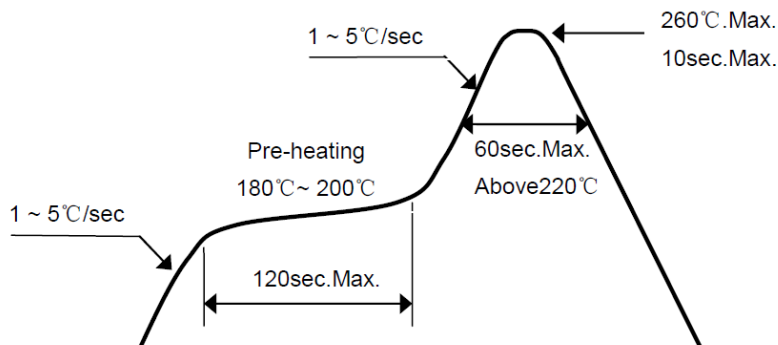



P-TEC

PL1515A-WCRGB1 Customer Approval Signatures	Approved By	Checked By	Prepared By

Record Of Revisions			
Rev.	Comments	Page	Date
0	Released Spec	--	01/12/15