

# PRODUCT SPECIFICATION

*Part Number*  
**PLBT2214A-WCB12**

## *Details*

- PLCC-2 2214 SMD LED
- 2.2mm x 1.4mm x 1.3mm
- Emitting Color: Amber
- AlInGaP chip material

## *Features*

- RoHS & REACH Compliant
- MSL2 qualified according to J-STD 020
- ESD 2KV-HBM: MIL-STD-883 Class 2

## *Mechanical Dimensions*

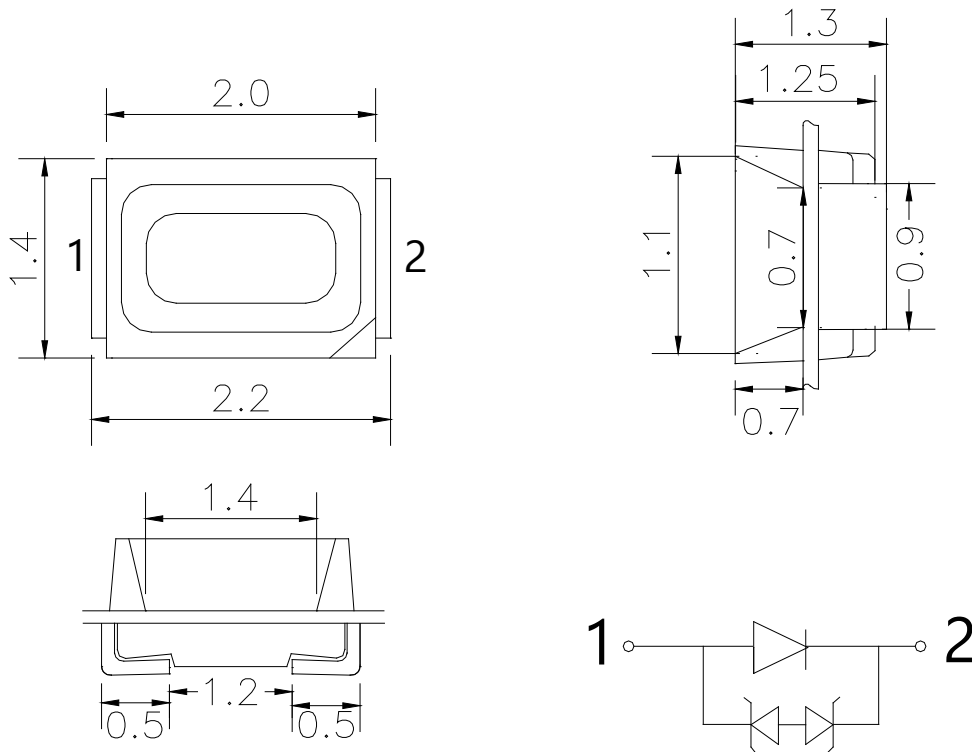

### Notes:

1. Specifications subject to change without notice
2. All dimensions are in millimeters unless otherwise noted
3. Tolerance is  $\pm 0.1$ mm unless otherwise noted



### Device Selection Guide

Model Number	Chip		Lens Type
	Material	Emitting Color	
PLBT2214A-WCB12	InGaN	Blue	Water Clear

### Absolute Maximum Ratings at Ta=25°C

Parameter	Symbol	Rating	Unit
DC Forward Current	IF	30	mA
Pulse Forward Current	IPF	100	mA
Reverse Voltage	Vr	5	V
Junction Temperature	Tj	115	°C
Thermal Resistance Junction / Solder Point	Rth	160	°C/W
Operating Temperature	Top	-40~+105	°C
Storage Temperature	Tstg	-40~+105	°C
Soldering Temperature	Tsol	260	°C

Notes 1: There is no maximum or typical voltage parameter

2: For other ambient, limited setting of current will be depended on de-rating curves.

3: Duty 1/10, pulse width 0.1ms

4: The maximum of soldering time is 5 seconds in TSD

### Electrical and Optical Characteristics at Ta=25°C

Parameter	Symbol	Min	Typ.	Max	Unit	Condition
Forward Voltage	IF	2.8	3.2	3.6	V	IF=20mA
Luminous Intensity	IV	160	270	--	mcd	
Dominant Wavelength	$\lambda_d$	462.5	--	472.5	nm	
Reverse Current	IR	--	--	10	$\mu$ A	Vr=5V
Viewing Angle	$2\theta_{1/2}$	--	120	--	deg	IF=20mA

Notes: 1. Measurement tolerances:

Forward Voltage:  $\pm 0.1V$ , Luminous Intensity:  $\pm 10\%I_v$ , Dominant Wavelength:  $\pm 1.0nm$

2. Electrical-Optical Characteristics (Ta=25°C)

### Recommended Pad Layout

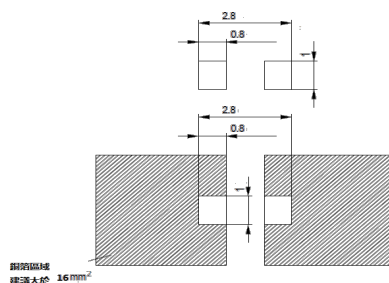



***Luminous Intensity Bins (IF=20mA)***

<b>Bin Code</b>	<b>Min IV (mcd)</b>	<b>Max IV (mcd)</b>
8	160	210
9	210	270
10	270	350
11	350	460

***Forward Voltage Bins (IF=20mA)***

<b>Bin Code</b>	<b>Min IV (mcd)</b>	<b>Max IV (mcd)</b>
B	2.8	2.9
C	2.9	3.0
D	3.0	3.1
E	3.1	3.2
F	3.2	3.3
G	3.3	3.4
H	3.4	3.5
I	3.5	3.6

***Dominant Wavelength Bins (IF=20mA)***

<b>Bin Code</b>	<b>Min <math>\lambda_d</math> (nm)</b>	<b>Max <math>\lambda_d</math> (nm)</b>
D	462.5	467.5
E	467.5	472.5

## Typical Electrical / Optical Characteristic Curves

1). Relative Spectral Distribution

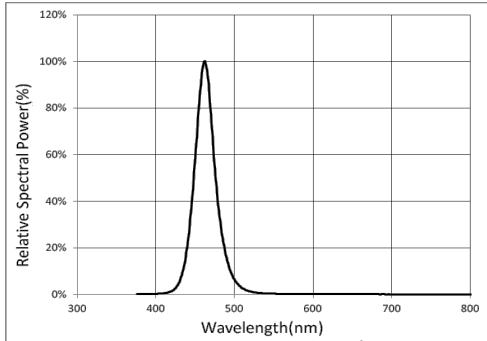

2). Typical Spatial Distribution

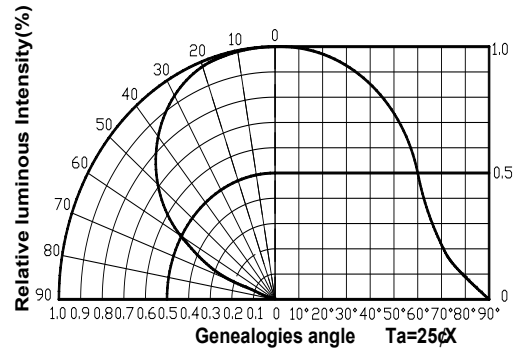

3). Relative Luminous Flux .Current

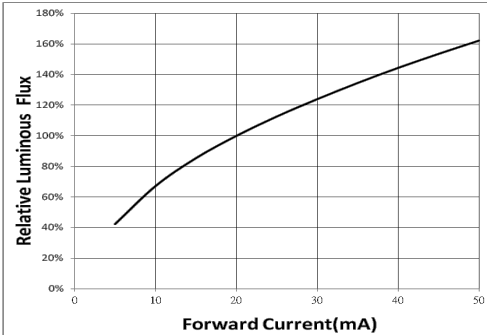

4). Relative Luminous Flux .Ambient Temperature

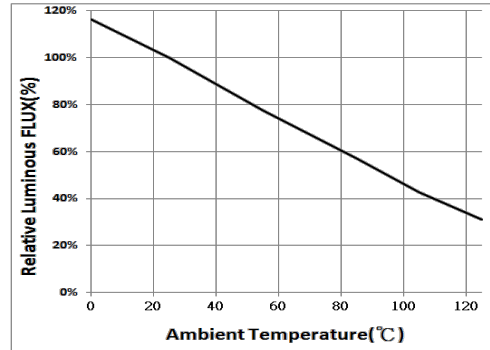

5). Electrical Characteristics

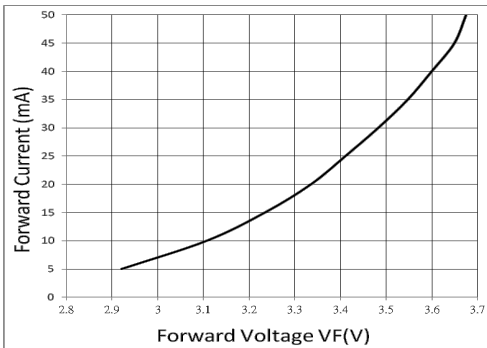

6). Relative Forward Voltage Temperatur

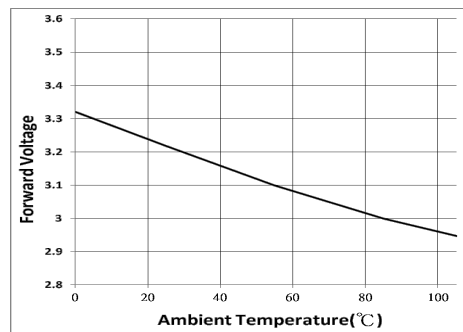

7). Relative Wavelength and Temperature

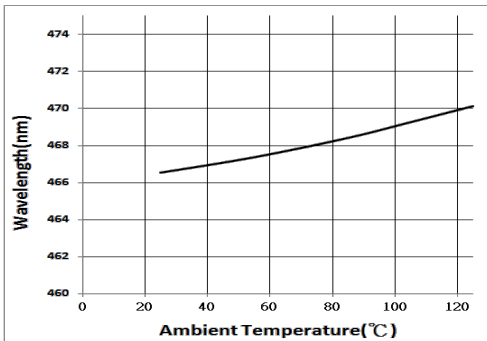

8). Thermal Design

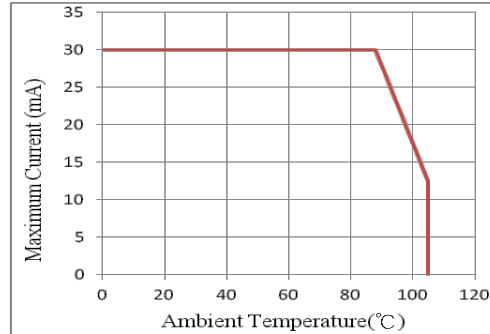

### IR Reflow Soldering Profile

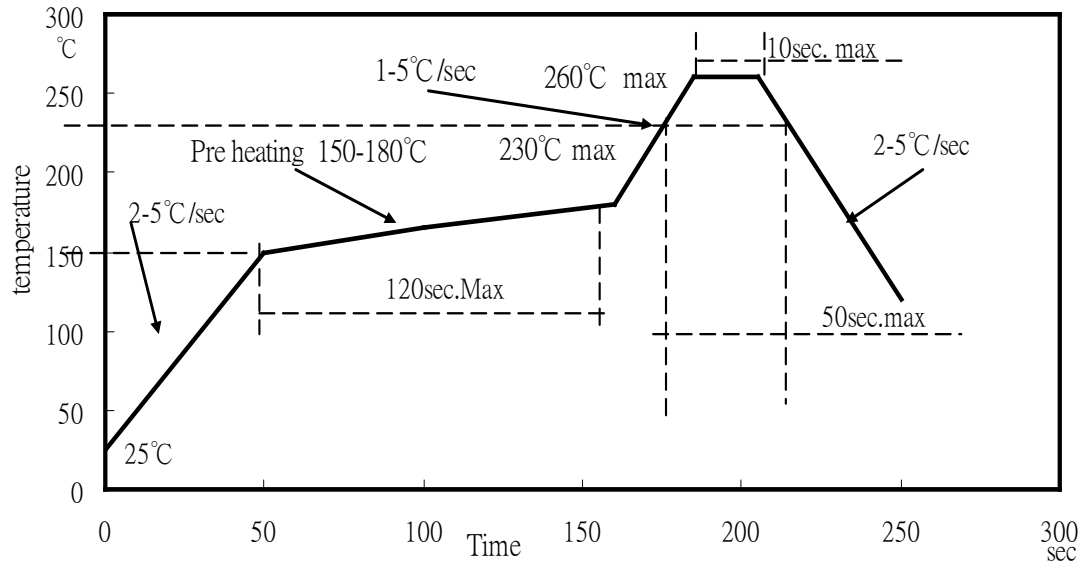

Notes:

1. We recommend the reflow temperature 240°C (±5°C) the maximum soldering temperature should be limited to 260°C.
2. Don't cause stress to the silicone resin while it is exposed to high temperature.
3. Number of reflow process shall be less than 3 times.

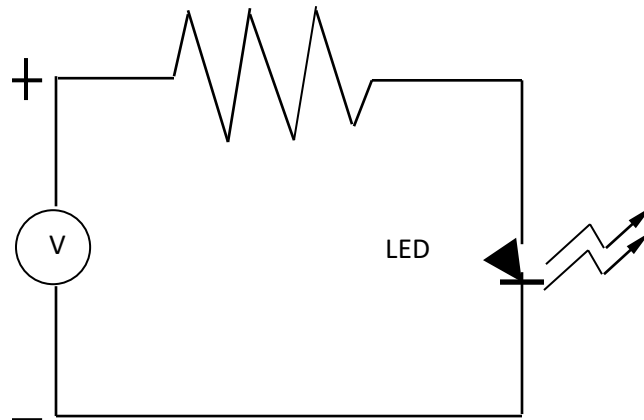

### Handling

#### 2.1. Over-current-proof

Customer must apply resistors for protection; otherwise slight voltage shift will cause big current change (Burn out will happen).



## 2.2. Storage

1). It is recommended to store the products in the following conditions:

Humidity: 60% R.H. Max.

Temperature: 5°C~30°C(41°F~86°F)

2). Shelf life in sealed bag: 12 month at <5°C~30°C and <60% R.H. after the package is Opened, the products should be used within four weeks or they should be keeping to stored at  $\leq 20\%$ R.H. with zip-lock sealed.

## 2.3. Baking

If the package has been opened for more than 4 weeks, it is recommended to bake the products with the following instruction:

1). 60±3°C X 6hrs and <5%RH, for reel

2). 125±3°C X 2hrs, for single LED

It shall be normal to see slight color fading of carrier (light yellow) after baking in process

***Test Items and Results of Reliability***

Test Item	Test Conditions	Duration/ Cycle	Ac/Re	Number of Damage	Reference
Normal Temperature Life	T <sub>a</sub> =23°C(±5°C) I <sub>F</sub> =20mA	1008 hrs	0/1	0/22	JESD22 A-108
High Temperature Life	T <sub>a</sub> = 85°C(±5°C) I <sub>F</sub> =20mA	1008 hrs	0/1	0/22	JESD22 A-108
High Humidity Heat Life	T <sub>a</sub> =85°C(±5°C) RH=85% I <sub>F</sub> =20mA	1008 hrs	0/1	0/22	JESD22 A-108
Thermal shock	- 45°C/30min~105°C/30min (±5°C)	1008 hrs	0/1	0/22	JESD22 A-104
Electrostatic Discharge (ESD) Test	According to the SPEC	3 cycles	0/1	0/22	AEC Q101-001
Low Temperature Storage	T <sub>a</sub> =-40°C	1008 hrs	0/1	0/22	JESD22-A103D
High Temperature Storage	T <sub>a</sub> =125°C	1008 hrs	0/1	0/22	JESD22-A103D

**\*Criteria for Judging**

Item	Symbol	Condition	Criteria for Judgment of Pass	
			Min	Max
Forward Voltage	V <sub>F</sub>	I <sub>F</sub> =20mA	-	USL <sup>*1</sup> ×1.1
Reverse Current	I <sub>R</sub>	V <sub>R</sub> = 10V	-	10μA
Luminous Intensity	I <sub>v</sub>	I <sub>F</sub> =20mA	LSL <sup>*2</sup> ×0.7	-

### Tape and Reel Dimensions

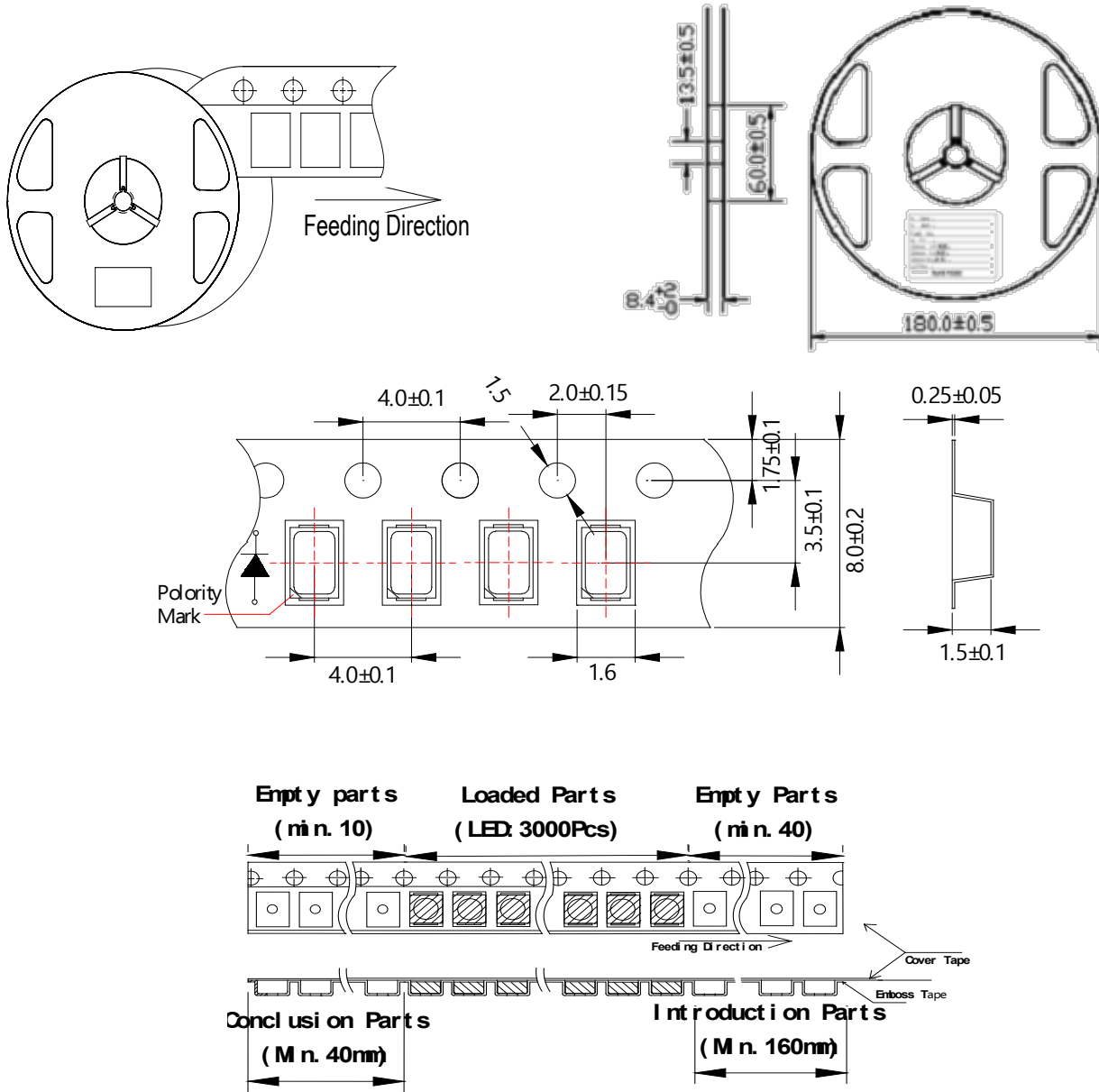

**Notes:**

1. Empty component pockets are sealed with top cover tape
2. The max loss number of SMD is 2pcs;
3. The cathode is oriented towards the tape sprocket hole in accordance with ANSI/EIA RS-481 specifications;
4. 3,000pcs per reel;
5. The remainder packing in multiples of 500pcs.



### *Packaging Specifications*

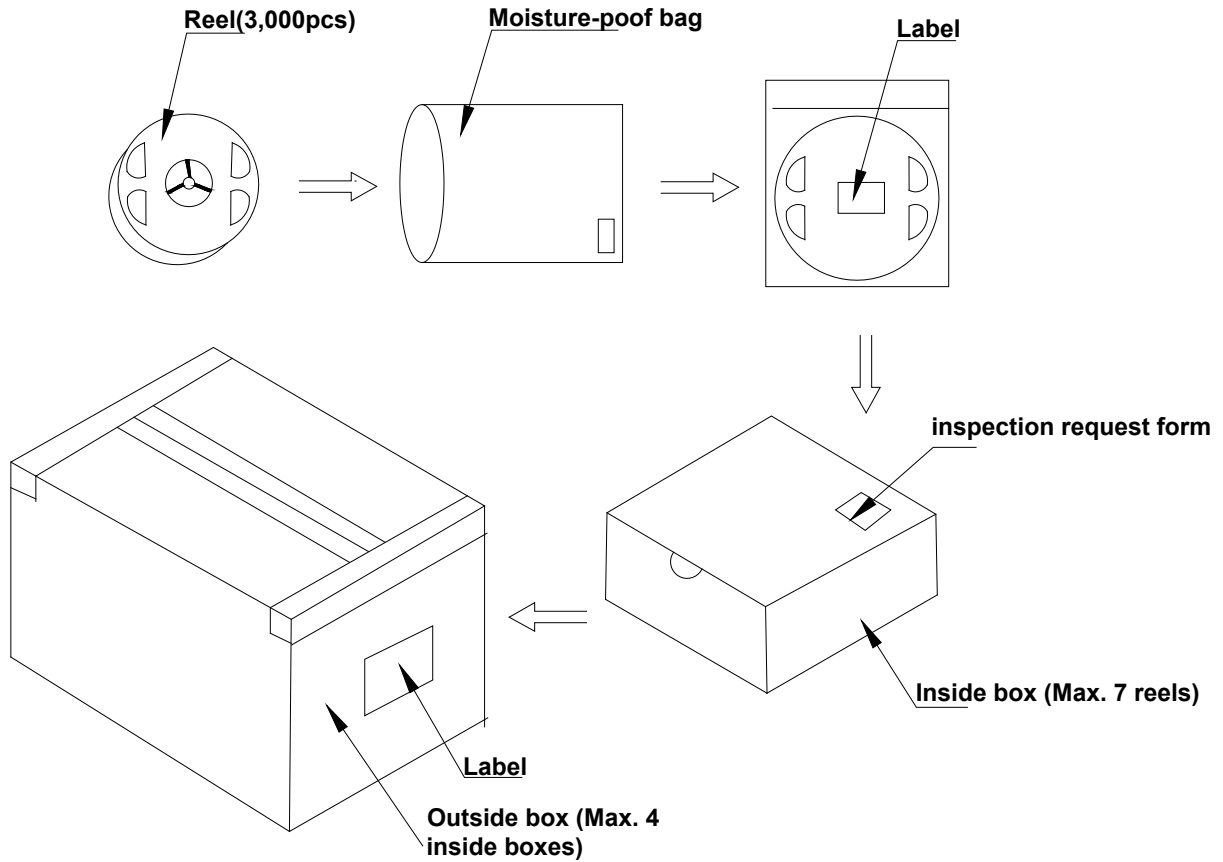

**Notes:**

Reeled product (max.3,000) is packed in a sealed moisture-proof bag. Seven bags are packed in an inner box (size: about 260 X 230 X 100 mm) and four inner boxes are in an outer box (size: about 480 X 275 X 215 mm). On the label of moisture-proof bag, there should be the information of Part No., Lot No. and quantity number; also the total quantity number should be on inspection request form on outer box.

## Precautions

### Abnormal situation caused by improper setting of collet

To choose the right collet is the key issue in improving the product's quality. LED is different from other electronic components, which is not only about electrical output but also for optical output. This characteristic made LED more fragile in the process of SMT. If the collet's lowering down height is not well set, it will bring damage to the gold wire at the time of collet's picking up and loading which will cause the LED fail to light up, light up now and then or other quality problems

### How to choose the collet

During SMT, please choose the collet that has larger outer diameter than the lighting area of lens, in case that improper position of collet will damage the gold wire inside the LED. Different collets fit for different products, please refer to the following pictures cross out

### Outer diameter of collet should be larger than the lighting area

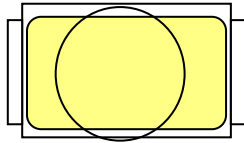

Picture 1(√)

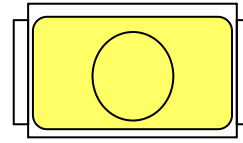

Picture 2(X)

### Other points for attention

- A. No pressure should be exerted to the epoxy shell of the SMD under high temperature.
- B. Do not scratch or wipe the lens since the lens and gold wire inside are rather fragile and cross out easy to break.
- C. LED should be used as soon as possible when being taken out of the original package, and should be stored in anti-moisture and anti-ESD package.

This usage and handling instruction is only for your reference.

