

PRODUCT SPECIFICATION

Part Number
PLH3537SB6-WCRGB1

Details

- 3.5 x 3.7 x 1.1mm RGB LED with integrated IC.

Applications

- Full color LED string light
- LED full color module
- LED guardrail tube
- LED scene lighting
- LED point light
- LED pixel screen
- LED shaped screen

Features

- 3537 with integrated high quality constant current IC and RGB LED chip.
- Built-in IC, with high precision of constant current and internal RGB chips spectral processing in advance.
- Single line data transmission (return to zero code).
- Specific Shaping Transmit Technology - number of LED stacked is not restricted.
- Dual-signal wires version, signal break-point continuous transmission. Any pixel's failure won't affect signal transfer and total emitting effect.
- Cascading Enhancement Technology - any 2 LED spacing can be up to 10 meters
- Data transfer rate of 800 kbp/s at 30 frames per second.
- RGB output port PWM control can achieve 256 grey level adjustments.
- Upon powering up, IC performs self-inspection then lights connection on the pin B lamp.
- SA-I Anti-interference patent technology for single line data transmission.
- Built-in power supply reverse connect protection module, reversed power input will not damage the IC.

Package Outline Dimensions & Pin Configuration

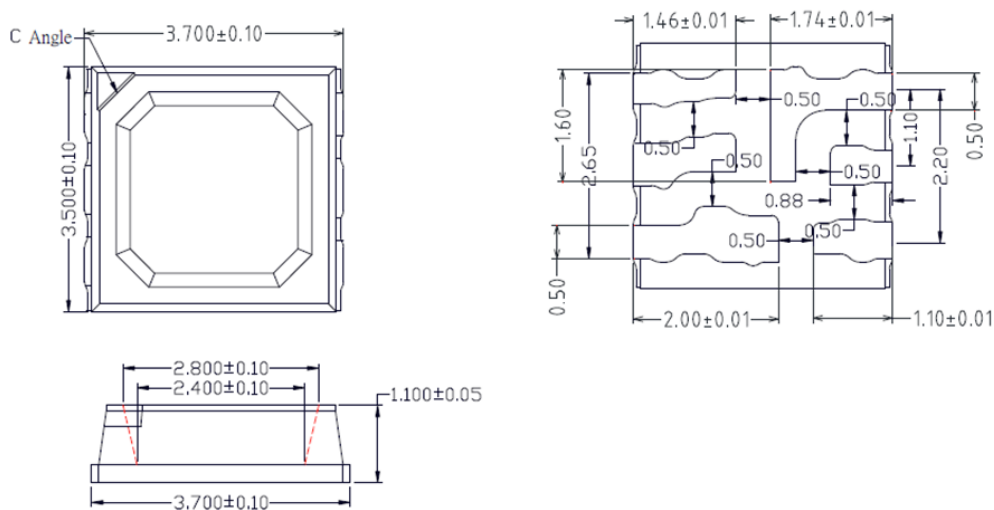

Note:

1. Specifications subject to change without notice



Pin Configuration

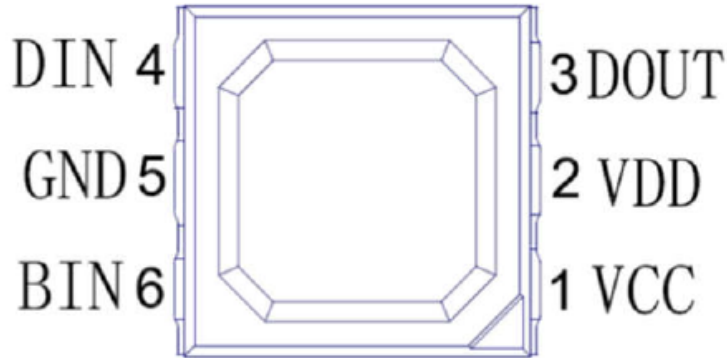

Notes:

1. All dimensions are in millimeters.
2. Tolerance is $\pm 0.1\text{mm}$ unless otherwise noted

Number	Symbol	Function Description
1	VCC	Power supply LED
2	VDD	Power supply LED
3	DOOUT	Control data signal output
4	DOIN	Control data signal input
5	GND	Ground
6	BIN	Control data signal input

Soldering Pad Size

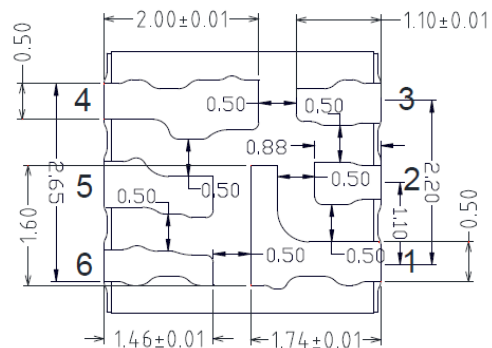
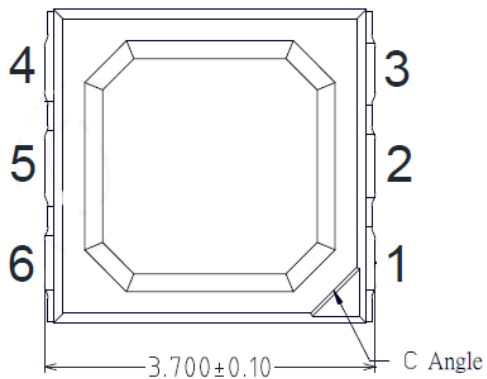

Absolute Maximum Rating ($T_a = 25\text{ }^\circ\text{C}$, $V_{SS}=0V$)

Parameter	Symbol	Range	Unit
Logic supply voltage	V_{DD}	+3.5~+5.5	V
Logic input voltage	V_{IN}	-0.5 ~VDD+0.5	V
Operating temperature	T_{OPT}	-45 ~ +85	°C
Storage temperature	T_{STG}	-50 ~ +150	°C
ESD pressure(HBM)	V_{ESD}	4K	V
ESD pressure(DM)	V_{ESD}	200	V

LED Characteristics ($T_a = 25^\circ\text{C}$)

Color	12mA	
	Wavelength(nm)	Light Intensity(mcd)
Red	620-630	400-700
Green	520-530	1000-1500
Blue	460-470	200-400

Recommended Operating Ranges

(unless otherwise specified, $T_a = -20 \sim +70 \text{ }^\circ\text{C}$, $V_{DD} = 4.5 \sim 5.5\text{V}$, $V_{SS} = 0\text{V}$)

Parameter	Symbol	Min.	Typ.	Max	Unit	Test conditions
Supply voltage	V_{DD}	-	5.2	-	V	-
R/G/B port pressure	$V_{DS, MAX}$	-	-	9	V	-
High level input voltage	V_{IH}	0.7*VDD	-		V	VDD=5.0V
Low level input voltage	V_{IL}	-	-	0.3*VDD	V	VDD=5.0V
The frequency of PWM	F_{PWM}	-	1.2	-	KHZ	-
Static power consumption	I_{DD}	-	1	-	mA	-

Switching Characteristics (unless otherwise specified, $T_A=25\text{ }^\circ\text{C}$)

Parameter	Symbol	Min.	Typ.	Max	Unit	Test conditions
The speed of data transmission	f_{DIN}	-	800	-	KHZ	The duty ratio of 67% (data 1)
DOOUT transmission delay	T_{PLH}	-	-	500	ns	DIN→DOOUT
	T_{PHL}	-	-	500	ns	
I_{OUT} Rise/Drop Time	T_r	-	100	-	ns	$V_{DS}=1.5$ $I_{OUT}=13\text{mA}$
	T_f	-	100	-	ns	

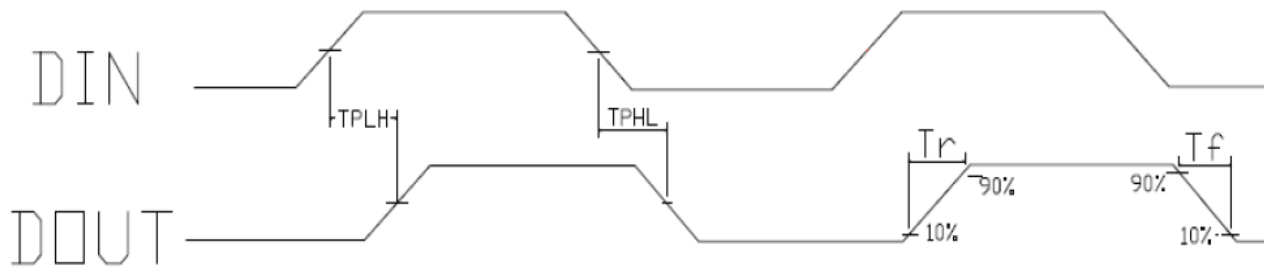

Timing Waveforms

1. Input Code

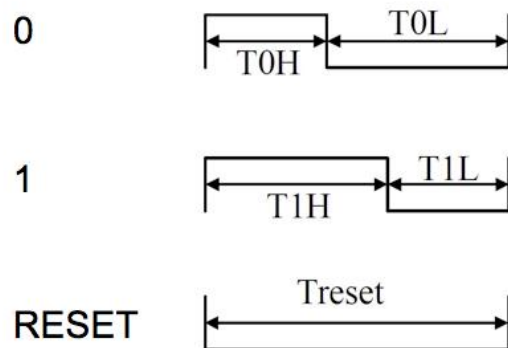

2. The data transmission time

Name	Description	Min.	Standard Value	Max.	Unit
T	Code Period	1.2	-	-	μs
T0H	0 code, high level time	0.2	0.32	0.4	μs
T0L	0 code, low level time	0.8	-	-	μs
T1H	1 code, high level time	0.62	0.64	1.0	μs
T1L	1 code, low level time	0.2	-	-	μs
Trst	Reset code, low level time	>80	-	-	μs

Note:

1. The protocol uses a unipolar zeroing code. Each symbol must have a low level. Each symbol in this protocol starts with a high level. The high time width determines the "0" or "1" code.
2. When writing programs, the minimum symbol period is 1.2μs.
3. The high time of "0" code and "1" code should be in accordance with the stipulated range in the above table. The low time requirement of "0" code and "1" code is less than 20μs.

3. Connection Scheme

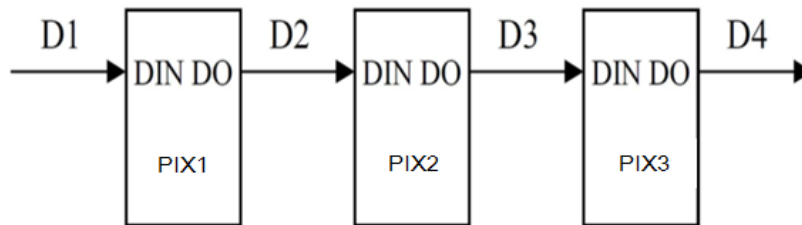

4. Data Transfer Format

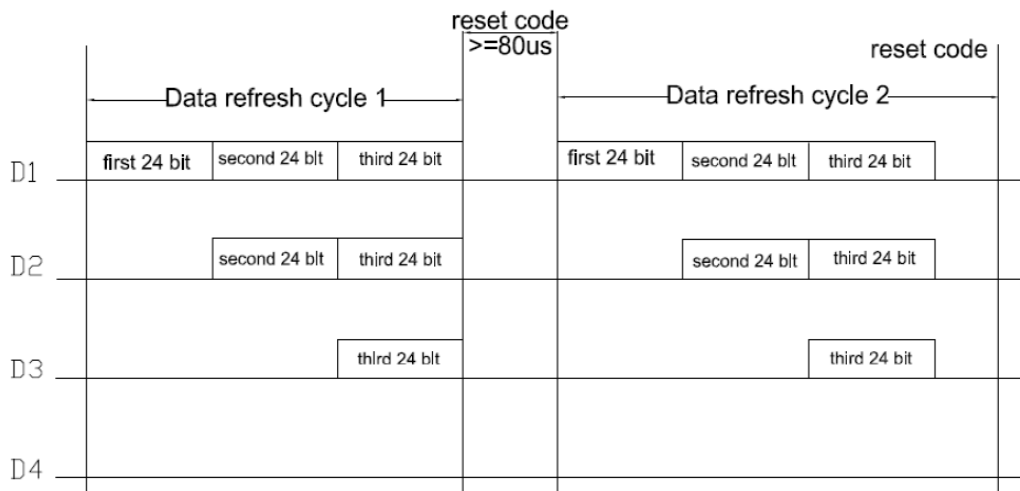

Note: the D1 sends data for MCU, D2, D3, D4 for data forwarding automatic shaping cascade circuit.

5. 24-bit data format

G7	G6	G5	G4	G3	G2	G1	G0	R7	R6	R5	R4
R3	R2	R1	R0	B7	B6	B5	B4	B3	B2	B1	B0

Note: high starting, in order to send data (G7 - G6 - B0)

Typical Application Circuit

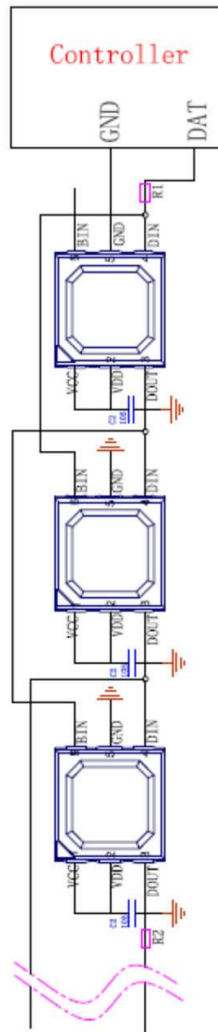

In the practical application circuit, the signal input and output pins of the IC signal input and output pins should be connected to the signal input and output terminals. In addition, in order to make the IC chip is more stable, even the capacitance between beads is essential back;

Application: used for soft lamp strip or hard light, lamp beads transmission distance is short, suggested in signal in time the clock line input and output end of each connected in series protection resistors, $R1=R0$ of about 330 ohms.

Application: for module or general special-shaped products, lamp beads transmission distance is long, because of different wire and transmission distance, in the signal in time clock at both ends of the line on grounding protection resistance will be slightly different; to the actual use of fixed;



LED Performance Graph

Thermal Pad Temperature vs. Relative Light Output

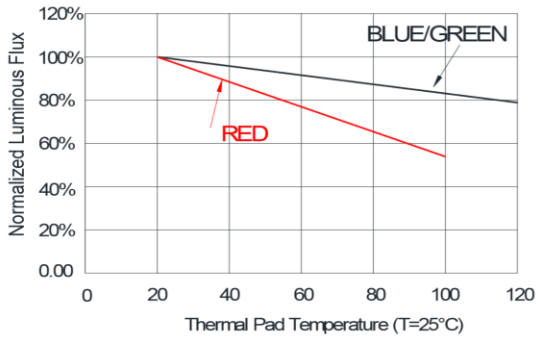

Wavelength Characteristics

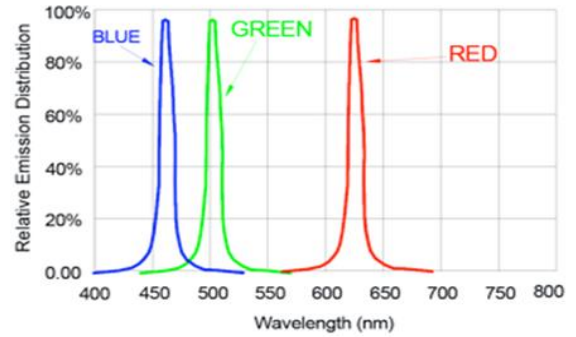

Typical Radiation Pattern 120°

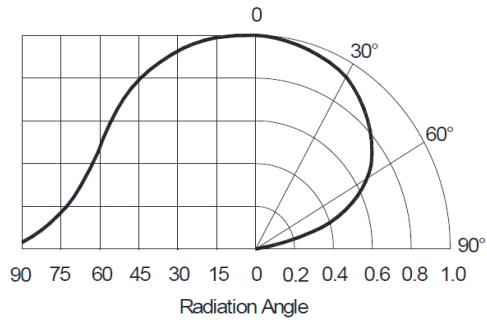



Precautions

Please read the following notes before using the product:

1. Storage

- 1.1 Do not open moisture proof bag before the products are ready to use.
- 1.2 Before opening the package, the LEDs should be kept at 30°C or less and 80%RH or less.
- 1.3 The LEDs should be used within a year.
- 1.4 After opening the package, the remaining LEDs should be kept in a resealed bag.
- 1.5 The LEDs require mandatory baking before usage. Baking treatment listed below.
- 1.6 If the moisture adsorbent material has fabled away or the LEDs have exceeded the storage time, baking treatment should be performed using the following conditions.

*Baking treatment: 60±5°C for 24 hours.

2. Soldering Condition

Recommended soldering conditions:

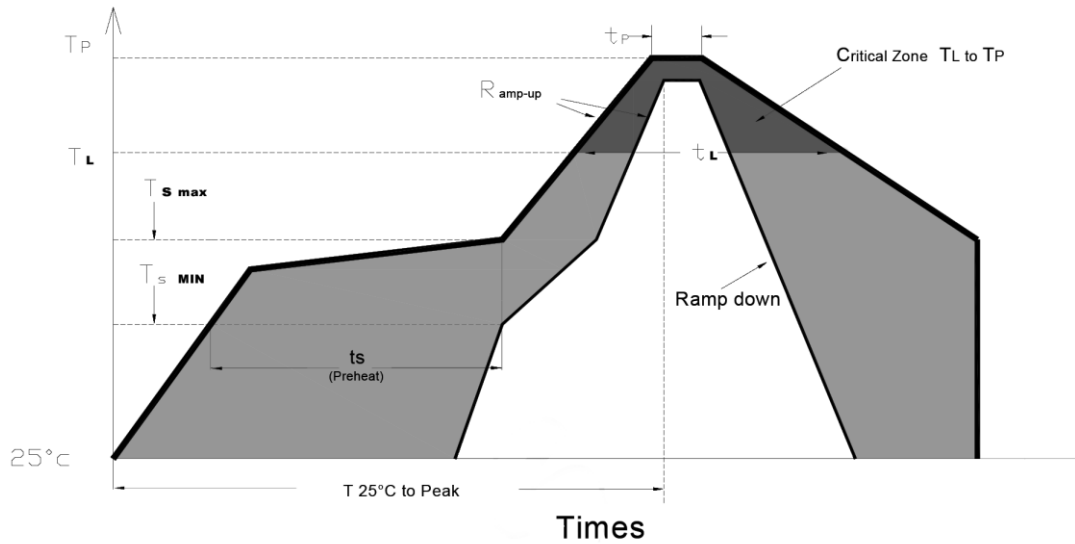

Profile Feature	Lead-Free Solder
Average Ramp-Up Rate (Ts max to Tp)	3°C/second max.
Preheat: Temperature Min (Ts min)	150°C
Preheat: Temperature Min (Ts max)	200°C
Preheat: Time (ts min to ts max)	60-180 seconds
Time Maintained Above: Temperature (Tl)	217 °C
Time Maintained Above: Time (tL)	60-150 seconds
Peak/Classification Temperature (Tp)	240 °C
Time Within 5°C of Actual Peak Temperature (tp)	<10 seconds
Ramp-Down Rate	6°C/second max.
Time 25 °C to Peak Temperature	<6 minutes max.

Note: Excessive soldering temperature and / or time might result in deformation of the LED lens or catastrophic failure of the LED.

3. Soldering Iron

Each terminal is to go to the tip of soldering iron temperature less than 260°C for 5 seconds within once in less than the soldering iron capacity 25W. Leave two seconds and more intervals, and do soldering of each terminal. Be careful because the damage of the product is often started at the time of the hand solder.

4. Repairing

Repair should not be done after the LEDs have been soldered. When repairing is unavoidable, a double-head soldering iron should be used (as below figure). It should be confirmed beforehand whether the characteristics of the LEDs will or will not be damaged by repairing.

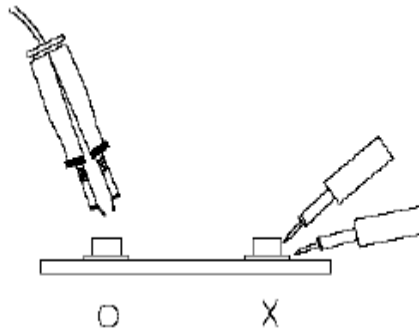

5. Caution in ESD

Static Electricity and surge damages the LED. It is recommended to use a wristband or anti-electrostatic glove when handling the LED. All devices, equipment and machinery must be properly grounded. Re: da

Record of Revisions			
Rev.	Comments	Page	Date
0	Released Spec	--	4/27/2021