



PRODUCT SPECIFICATION

Part Number

PT1076104A-MLMWF-EC03

CUSTOMER	
CUSTOMER PART NUMBER	
DESCRIPTION	10.4" TFT LCD, USB PCT
APPROVED BY	
DATE	

**P-TEC****MODEL NO.**

PT1076104A-MLMWF-EC03

**SPEC &
SAMPLE****PAGE**

2

1. Table of Contents

No.	Contents	Page
1	Table of Contents	2
2	Record of Revisions	3
3	Module Numbering System	4
4	Application	5
5	Features	5
6	General Specifications	5
7	Absolute Maximum Ratings	6
8	Electrical Characteristics	7
9	Block Diagram	10
10	Input / Output Terminals Pin Assignment	11
11	Interface Timing	14
12	Optical Characteristics	18
13	Reliability Test	21
14	Packaging	22
15	Precautions	23
16	Outline Drawing	25
17	Definition of Labels	26
18	Incoming Inspection Standards	28



3. Module Numbering System

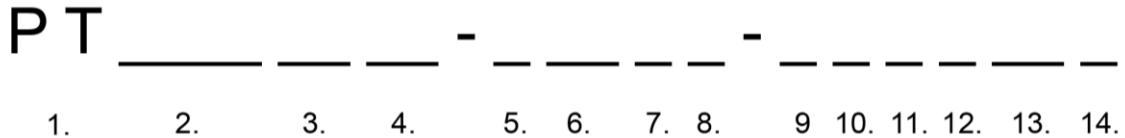

1. P-TEC TFT

2. LENGTH x WIDTH PIXELS

If third character is a zero, it is removed to shorten part number. Example: 240 x 320 = PT3224

3. DIAGONAL DIMENSIONS

Example: 3.5" display = 35 in part number

4. PRODUCT VERSION

Series assigned by P-tec

5. LCD MODE

T: TN
I: IPS
V: VA

6. POLARIZER

LM: Transmissive
LF: Transflective

7. BACKLIGHT COLOR

No Backlight: Left Blank
W: White
B: Blue/Green
S: Yellow/Green

8. VIEWING DIRECTION

D: 6 o'clock
U: 12 o'clock
F: Full Viewing Angle

9. A ~ Z CODE

Assigned by P-tec

11. TEMPERATURE RANGE

Normal: Left Blank
Wide: X

12. LUMINANCE

Blank: Normal (<300 nit)
M: Middle (>= 300 nit)
H: High (> 600 nit)

13. TOUCH PANEL OPTION

No TP: Left Blank
C: Capacitive TP
R: Resistive TP

14. SPECIAL CHARACTERS

Customer special requirements



4. Application

This specification is applied to the 10.4 inch XGA supported TFT-LCD module, and can display true 16.2M colors (6-bits colors with FRC). The module is designed for OA, Car TV application and other electronic products which require flat panel display of digital signal interface. This module is composed of a 10.4" TFT-LCD panel, a driver circuit and backlight unit and used as the input devices for general electric appliances via both finger and Capacitive stylus pen.

5. Features

- XGA (1024x768 pixels) resolution.
- 6 bit & 8 bit LVDS Interface
- Dot inversion mode with stripe type.
- MVA type
- Projected Capacitive Touch
 - USB Interface
 - Multi Touch (Ten points)

6. General Specifications

Item	Specifications	Unit
Screen Size	10.4 (Diagonal)	inch
Display Format	1024RGB(H)×768(V)	dot
Active Area	210.4(H)×157.8(V)	mm
Pixel Pitch	0.0685(H)×0.2055(V)	mm
Pixel Configuration	RGB Vertical Stripe	-
Display Mode	VA Type Transmissive Mode Normally Black	-
Surface Treatment	Clear(7H)	-
Viewing Direction	Full view angle	-
Outline Dimension	238.6(W)×175.8(H)×10.09(D)	mm
Weight	501.5	g
RoHS Compliance	P-TEC certifies this product to be in compliance with European Union Directive 2011/65/EU on the restriction of certain hazardous substances in electrical and electronic equipment.	-



7. Absolute Maximum Ratings

7.1 Absolute Ratings of Environment

Item	Symbol	Value		Unit	Note
		Min.	Max.		
Storage Temperature	T _{ST}	-20	+70	°C	(1)(2)
Operating Ambient Temperature	T _{OP}	-20	+70	°C	(1)(2)

Note (1) Temperature and relative humidity range is shown in the figure below.

- (a) 90 %RH Max. ($T_a \leq 40$ °C).
- (b) Wet-bulb temperature should be 39 °C Max. ($T_a > 40$ °C).
- (c) No condensation

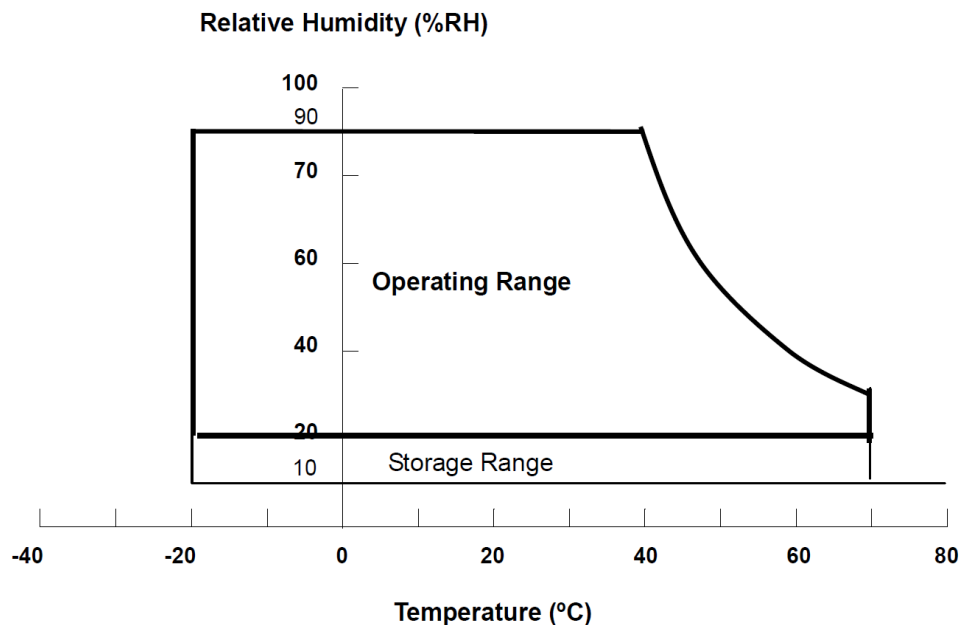

7.2 Electrical Absolute Ratings

7.2.1 TFT-LCD Module

Item	Symbol	Value		Unit	Note
		Min.	Max.		
Power Supply Voltage	VCC	-0.3	7	V	(1)

7.2.2 LED CONVERTER

Item	Symbol	Value		Unit	Note
		Min.	Max.		
Converter Voltage	V _i	-0.3	22	V	(1), (2)
Enable Voltage	EN	---	5.5	V	
Backlight Adjust	ADJ	---	5.5	V	

Note (1) Permanent damage to the device may occur if maximum values are exceeded. Function operation should be restricted to the conditions described under Normal Operating Conditions.

Note (2) Specified values are for LED light ba (Refer to 8.2 for further information).



8. Electrical Characteristics

8.1 TFT-LCD Module

(Ta=25±2°C)

ITEM	SYMBOL	MIN	TYP	MAX	UNIT	NOTE
Power Supply Voltage	VCC	3.0	3.3	3.6	V	(1)
Rush Current	Irush	-	-	4.0	A	(2)
Power Supply Current	White	530	570	620	mA	(3)
	Black	380	420	460	mA	
Power Consumption	PL	-	1.9	-	W	
LVDS Differential Input voltage	VID	100	-	600	mV	-
LVDS Common Mode Voltage	VICM	0.7	-	1.6	V	-

Note (1) The assembly should be always operated within above ranges.

Note (2) Measurement Conditions:

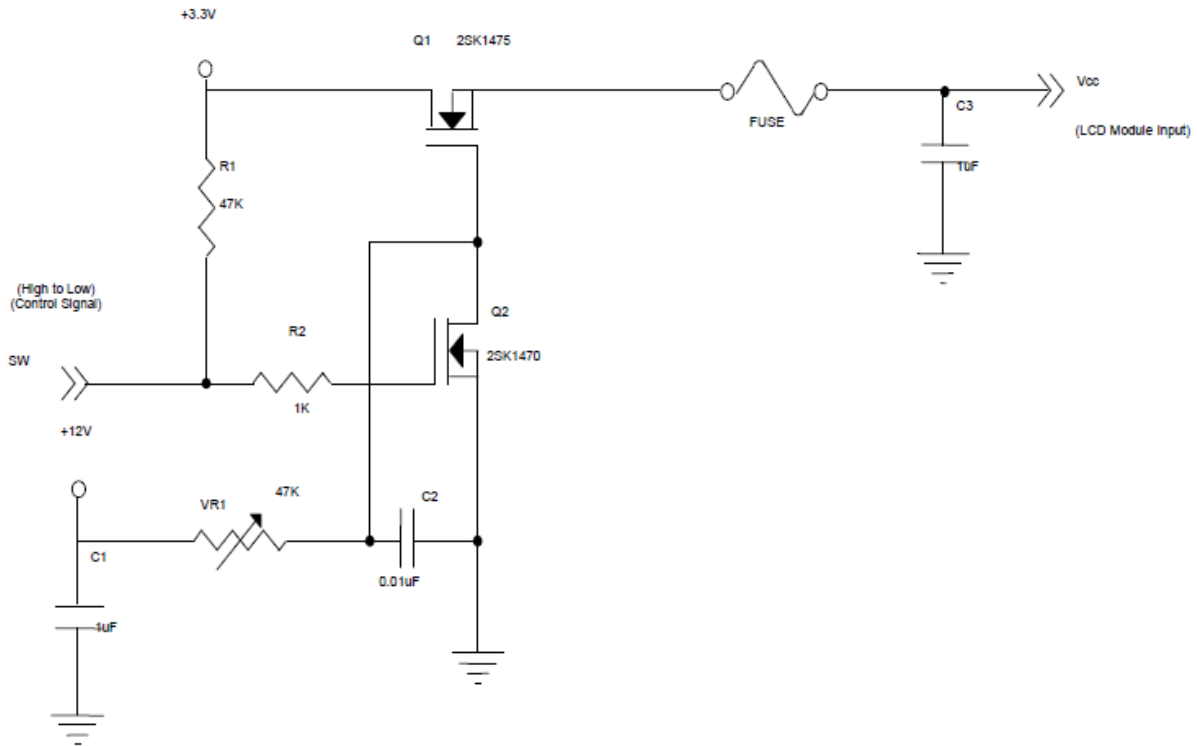

VCC rising time is 470us

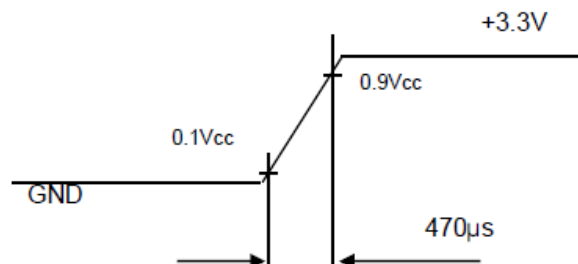



Note (3) The specified power consumption is under the conditions at $V_{cc}=3.3V$, $F_V=60Hz$, whereas a power dissipation check pattern below is displayed.

a. White Pattern



Active Area

b. Black Pattern

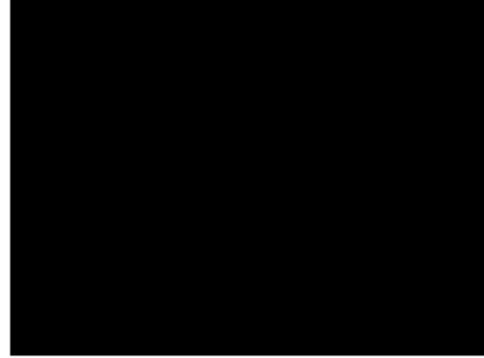

Active Area

8.2 Backlight Unit

($T_a=25\pm 2^\circ C$)

Parameter	Symbol	Value			Unit	Note
		Min.	Typ.	Max.		
Converter Power Supply Voltage	V_i	7	12.0	17	V	(Duty 100%)
Converter Power Supply Current	I_i	---	0.28	---	A	@ $V_i = 12V$ (Duty 100%)
LED Power Consumption	P_{LED}	---	3.1	---	W	@ $V_i = 12V$ (Duty 100%)
EN Control Level	Backlight on	2.0	---	5	V	
	Backlight off	0	---	0.8	V	
PWM Control Level	PWM High Level	2.0	---	5	V	
	PWM Low Level	0	---	0.15	V	
PWM Control Duty Ratio		2		100	%	
PWM Control Frequency	f_{PWM}	190	200	20k	Hz	(2)
LED Life Time	L_L	30,000			Hrs	(3)

Note (1) LED current is measured by utilizing a high frequency current meter as shown below:

Note (2) At 190 ~1KHz PWM control frequency, duty ratio range is restricted from 2% to 100%.

1K ~20KHz PWM control frequency, minimum duty on-time ≥ 20 us.

Note (3) The lifetime of LED is defined as the time when it continues to operate under the conditions at

$T_a = 25 \pm 2^\circ C$ and $I_{LED} = 20mA_{DC}$ (LED forward current) until the brightness becomes $\leq 50\%$ of its original value. Operating LED under high temperature environment will reduce life time and lead to color shift.



8.3 Projected Capacitive Touch

Item	Symbol	Value			Unit	Note
		Min.	Typ.	Max.		
Operating Voltage	VDD	4.8	5.0	5.2	V	-
Output High Threshold Voltage	V _{OH}	2.8	-	-	V	-
Output Low Threshold Voltage	V _{OL}	-	-	0.8	V	-
Differential Input Sensitivity (D+)-(D-)	V _{DI}	0.2	-	-	V	-
Differential Input Common Mode Range	V _{CM}	0.8	-	2.5	V	-
Power Supply Current	IDD	-	31.2	43.7	mA	(1)
Power Consumption	P _L	-	156.0	218.5	mW	@5.0V
Interface		USB				-
Function		Multi Touch				-

Note (1) This test condition is touched with 10 points.



9. Block Diagram

9.1 TFT-LCD Module with Backlight Unit

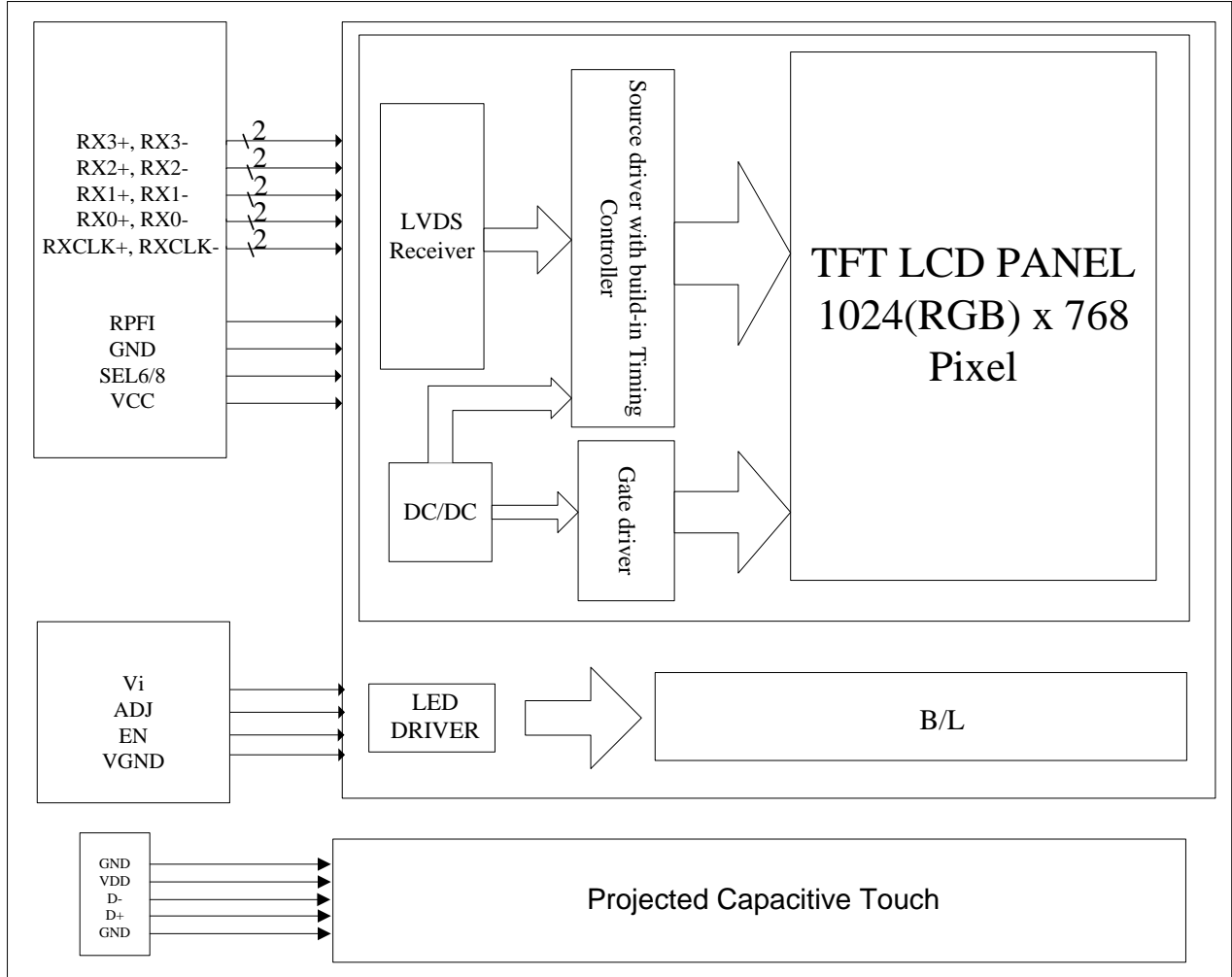

**10. Input / Output Terminals Pin Assignment****10.1 TFT-LCD Module**

CN1 Connector Pin Assignment

Pin No.	Symbol	Description	Note
1	VCC	Power supply: +3.3V	-
2	VCC	Power supply: +3.3V	-
3	VCC	Power supply: +3.3V	-
4	GND	Ground	-
5	GND	Ground	-
6	GND	Ground	-
7	RPFI	Reverse Panel Function (Display Rotation)	(2)
8	NC	No Connection	
9	NC	No Connection	-
10	NC	No Connection	-
11	SEL6/8	LVDS 6/8 bit select function control, Low or NC → 8 bit Input Mode High → 6bit Input Mode	(2)
12	GND	Ground	-
13	NC	No Connection	-
14	GND	Ground	-
15	RX0-	Negative transmission data of pixel 0	-
16	RX0+	Positive transmission data of pixel 0	-
17	GND	Ground	-
18	RX1-	Negative transmission data of pixel 1	-
19	RX1+	Positive transmission data of pixel 1	-
20	GND	Ground	-
21	RX2-	Negative transmission data of pixel 2	-
22	RX2+	Positive transmission data of pixel 2	-
23	GND	Ground	-
24	RXCLK-	Negative of clock	-
25	RXCLK+	Positive of clock	-
26	GND	Ground	-
27	RX3-	Negative transmission data of pixel 3	-
28	RX3+	Positive transmission data of pixel 3	-
29	GND	Ground	-
30	NC	No Connection	(2)

Note (1) Connector Part No.: JAE, FI-XB30SRL-HF11 or compatible connector

Note (2) "Low" stands for 0V. "High" stands for 3.3V. "NC" stands for "No Connected"



10.2 Backlight

Pin	Symbol	Description	Remark
1	V_i	Converter input voltage	12V
2	V_i	Converter input voltage	12V
3	V_i	Converter input voltage	12V
4	V_i	Converter input voltage	12V
5	V_{GND}	Converter ground	Ground
6	V_{GND}	Converter ground	Ground
7	V_{GND}	Converter ground	Ground
8	V_{GND}	Converter ground	Ground
9	EN	Enable pin	3.3V
10	ADJ	Backlight Adjust	PWM Dimming

Note (1) Connector Part No.: 91208-01001(ACES) or equivalent

Note (2) User's connector Part No.: 91209-01011(ACES) or equivalent

10.3 Projected Capacitive Touch

Connector : CVILUX CI0105M1HR0-NH

No.	Symbol	Functions
1	VDD	+5.0V power supply.
2	D-	USB D-
3	D+	USB D+
4	GND	System ground.
5	NC	Not Connection



10.4 Color Data Input Assignment

The brightness of each primary color(red, green and blue) is based on the 8 bit gray scale data input for the color. The higher the binary input, the brighter the color. The table provides the assignment of color versus data input.

Color		Data Signal																							
		Red								Green								Blue							
		R7	R6	R5	R4	R3	R2	R1	R0	G7	G6	G5	G4	G3	G2	G1	G0	B7	B6	B5	B4	B3	B2	B1	B0
Basic Colors	Black	0	0	0	0	0	0	0	0	0	0	0	0	0	0	0	0	0	0	0	0	0	0	0	
	Red	1	1	1	1	1	1	1	1	0	0	0	0	0	0	0	0	0	0	0	0	0	0	0	
	Green	0	0	0	0	0	0	0	0	1	1	1	1	1	1	1	0	0	0	0	0	0	0	0	
	Blue	0	0	0	0	0	0	0	0	0	0	0	0	0	0	0	1	1	1	1	1	1	1	1	
	Cyan	0	0	0	0	0	0	0	0	1	1	1	1	1	1	1	1	1	1	1	1	1	1	1	
	Magenta	1	1	1	1	1	1	1	1	0	0	0	0	0	0	0	1	1	1	1	1	1	1	1	
	Yellow	1	1	1	1	1	1	1	1	1	1	1	1	1	1	1	0	0	0	0	0	0	0	0	
	White	1	1	1	1	1	1	1	1	1	1	1	1	1	1	1	1	1	1	1	1	1	1	1	
Gray Scale Of RED	Red(0) / Dark	0	0	0	0	0	0	0	0	0	0	0	0	0	0	0	0	0	0	0	0	0	0		
	Red(1)	0	0	0	0	0	0	1	0	0	0	0	0	0	0	0	0	0	0	0	0	0	0		
	Red(2)	0	0	0	0	0	0	1	0	0	0	0	0	0	0	0	0	0	0	0	0	0	0		
	:	:	:	:	:	:	:	:	:	:	:	:	:	:	:	:	:	:	:	:	:	:	:		
	:	:	:	:	:	:	:	:	:	:	:	:	:	:	:	:	:	:	:	:	:	:	:		
	Red(253)	1	1	1	1	1	1	0	1	0	0	0	0	0	0	0	0	0	0	0	0	0	0		
	Red(254)	1	1	1	1	1	1	1	0	0	0	0	0	0	0	0	0	0	0	0	0	0	0		
	Red(255)	1	1	1	1	1	1	1	1	0	0	0	0	0	0	0	0	0	0	0	0	0	0		
Gray Scale Of Green	Green(0) / Dark	0	0	0	0	0	0	0	0	0	0	0	0	0	0	0	0	0	0	0	0	0	0		
	Green(1)	0	0	0	0	0	0	0	0	0	0	0	0	0	0	1	0	0	0	0	0	0	0		
	Green(2)	0	0	0	0	0	0	0	0	0	0	0	0	0	1	0	0	0	0	0	0	0	0		
	:	:	:	:	:	:	:	:	:	:	:	:	:	:	:	:	:	:	:	:	:	:	:		
	:	:	:	:	:	:	:	:	:	:	:	:	:	:	:	:	:	:	:	:	:	:	:		
	Green(253)	0	0	0	0	0	0	0	0	1	1	1	1	1	1	0	1	0	0	0	0	0	0		
	Green(254)	0	0	0	0	0	0	0	0	1	1	1	1	1	1	0	0	0	0	0	0	0	0		
	Green(255)	0	0	0	0	0	0	0	0	1	1	1	1	1	1	1	0	0	0	0	0	0	0		
Gray Scale Of Blue	Blue(0) / Dark	0	0	0	0	0	0	0	0	0	0	0	0	0	0	0	0	0	0	0	0	0	0		
	Blue(1)	0	0	0	0	0	0	0	0	0	0	0	0	0	0	0	0	0	0	0	0	0	1		
	Blue(2)	0	0	0	0	0	0	0	0	0	0	0	0	0	0	0	0	0	0	0	0	0	1		
	:	:	:	:	:	:	:	:	:	:	:	:	:	:	:	:	:	:	:	:	:	:	:		
	:	:	:	:	:	:	:	:	:	:	:	:	:	:	:	:	:	:	:	:	:	:	:		
	Blue(253)	0	0	0	0	0	0	0	0	0	0	0	0	0	0	0	1	1	1	1	1	1	0		
	Blue(254)	0	0	0	0	0	0	0	0	0	0	0	0	0	0	0	1	1	1	1	1	1	0		
	Blue(255)	0	0	0	0	0	0	0	0	0	0	0	0	0	0	0	1	1	1	1	1	1	1		



11. Interface Timing

11.1 Input Signal Characteristics

Timing Characteristics

Signal	Item	Symbol	Min.	Typ.	Max.	Unit	Note
DCLK	Frequency	Fc	55	65	75	MHz	
Vertical Active Display Term	Total	Tv	770	806	950	Th	Tv=Tvd+Tvb
	Display	Tvd	768	768	768	Th	-
	Blank	Tvb	2	38	182	Th	-
Horizontal Active Display Term	Total	Th	1104	1344	1800	Tc	Th=Thd+Thb
	Display	Thd	1024	1024	1024	Tc	-
	Blank	Thb	76	320	776	Tc	-

Note (1) Since this assembly is operated in DE only mode, Hsync and Vsync input signals should be set to low logic level. Otherwise, this assembly would operate abnormally.

(2) Frame rate is 60Hz

INPUT SIGNAL TIMING DIAGRAM

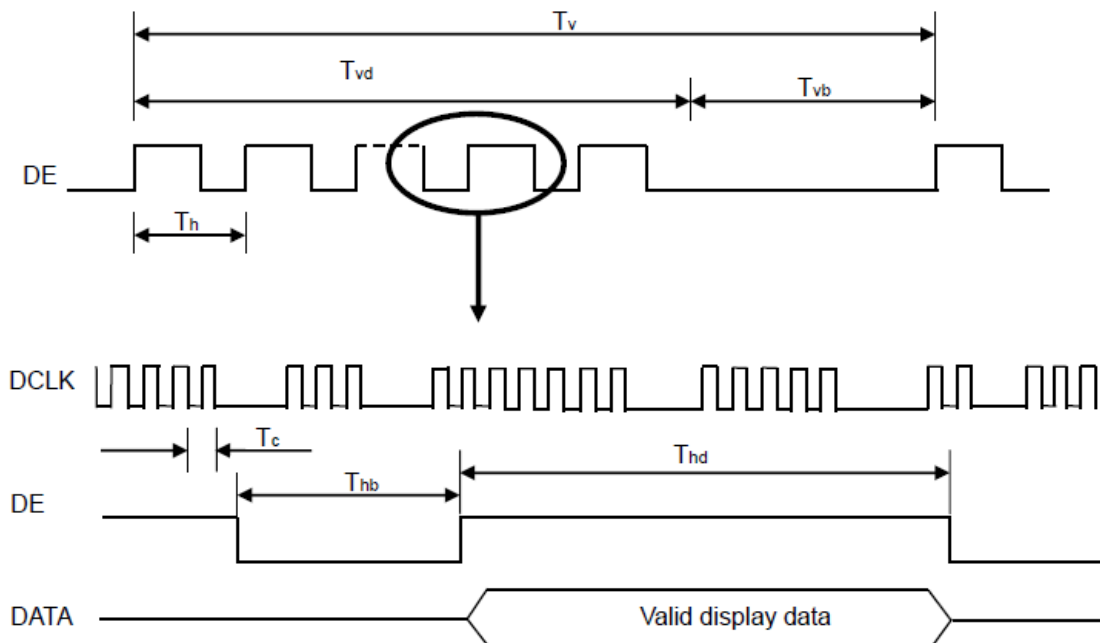



11.2 The Input Data Format

SEL 6/8 = "High" for 6 bits LVDS Input

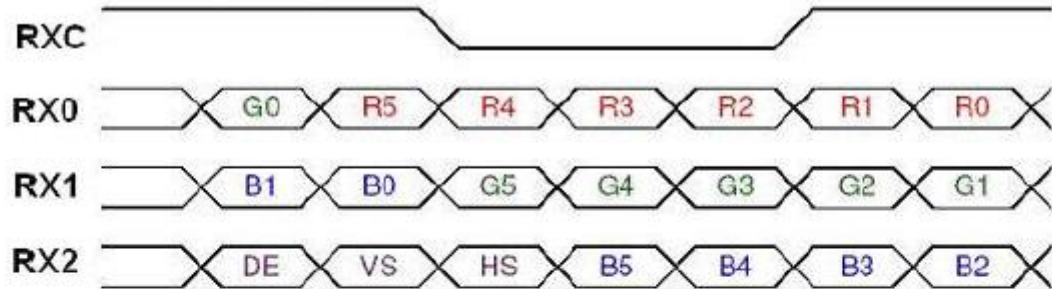

SEL 6/8 = "Low" or "NC" for 8 bits LVDS Input

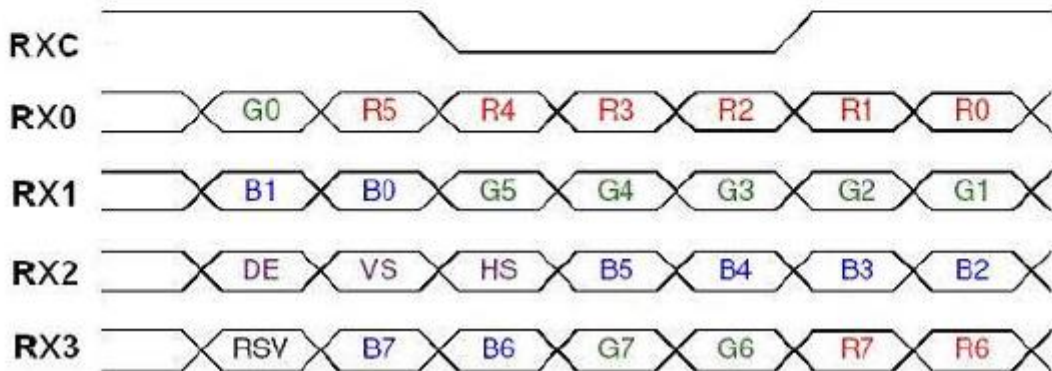



11.3 Power Sequence

To prevent a latch-up or DC operation of LCD assembly, the power on/off sequence should be as the diagram below.

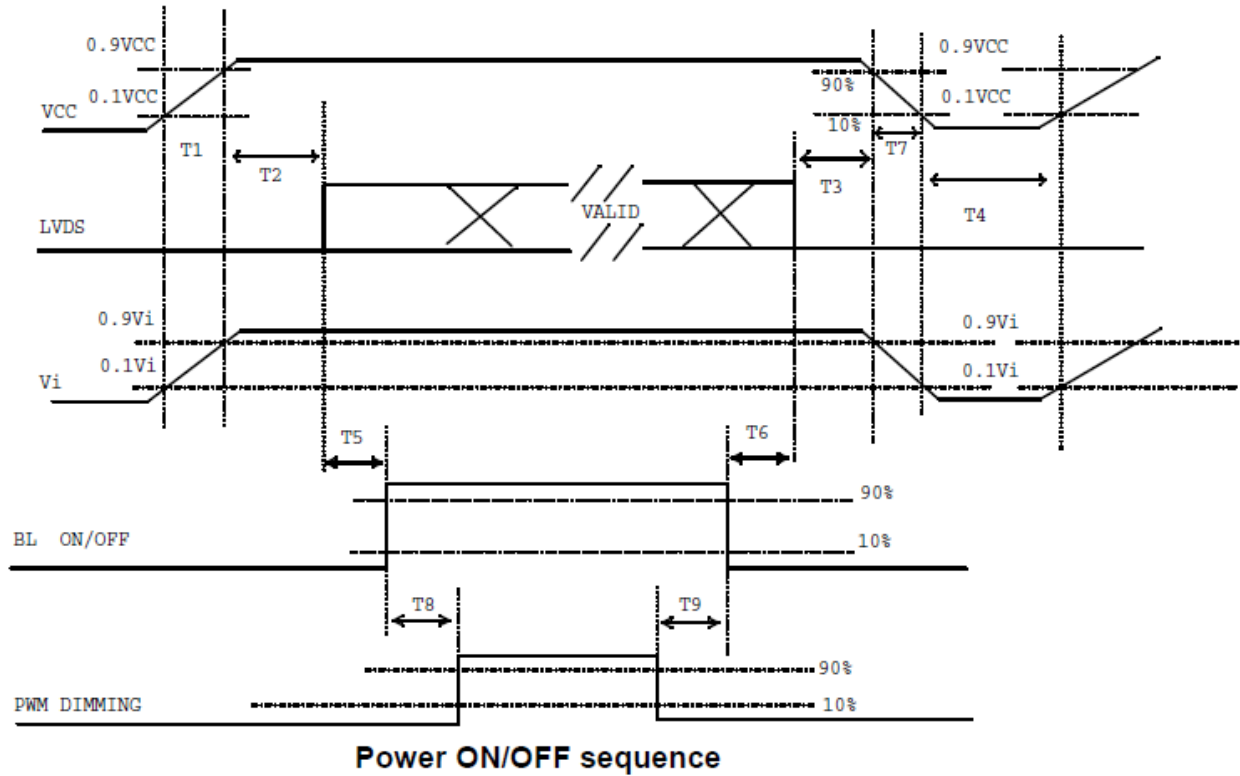

Note (1) Please avoid floating state of interface signal at invalid period.

Note (2) When the interface signal is invalid, be sure to pull down the power supply of LCD VCC to 0 V.

Note (3) The Backlight converter power must be turned on after the power supply for the logic and the interface signal is valid. The Backlight converter power must be turned off before the power supply for the logic and the interface signal is invalid.

Parameter	Value			Units
	Min	Typ	Max	
T1	0.5	-	10	ms
T2	0	-	50	ms
T3	0	-	50	ms
T4	500	-	-	ms
T5	200	-	-	ms
T6	20	-	-	ms
T7	5	-	300	ms
T8	10	-	-	ms
T9	10	-	-	ms



11.4 Scanning Direction

The following figures show the image see from the front view. The arrow indicates the direction of scan.



RPI = Low/floating; normal display (default)



RPI = high: display with 180degree rotation

11.5 USB Interface

11.5.1 Single Touch Function

Single Touch Function works with plug'n play under system Windows 2000, Windows XP and Windows7.

For other operating systems like Linux a driver must be programmed.

11.5.2 Multi Touch Function

The Multi Touch Function works with plug'n play under system Windows7.

For older Windows systems or other operating systems a driver must be programmed.



12. Optical Characteristics

The optical characteristics should be measured in a dark environment (≤ 1 lux) or equivalent state with the methods shown in Note (4).

Item		Symbol	Conditions	Min.	Typ.	Max.	Unit	Note
Contrast Ratio		CR	$\theta_x=0^\circ, \theta_y=0^\circ$ Viewing Normal Angle	700	1000	-	-	(2)
Response Time		T_{R+T_F}		-	25	35	ms	(3)
Luminance(Center)		Y		260	310	-	cd/m ²	(4)
White Variation		δW		-	-	1.4		(5)
Color Chromaticity	Red	Rx		0.560	0.610	0.660	-	(1),(4)
		Ry	0.315	0.365	0.415	-		
	Green	Gx	0.291	0.341	0.391	-		
		Gy	0.514	0.564	0.614	-		
	Blue	Bx	0.097	0.147	0.197	-		
		By	0.037	0.087	0.137	-		
	White	Wx	0.263	0.313	0.363	-		
		Wy	0.279	0.329	0.379	-		
Viewing Angle	Horizontal	θ_{x+}	CR \geq 10	80	88	-	deg.	
		θ_{x-}		80	88	-		
	Vertical	θ_{y+}		80	88	-		
		θ_{y-}		80	88	-		



Note (1) Definition of Viewing Angle (θ_x , θ_y):

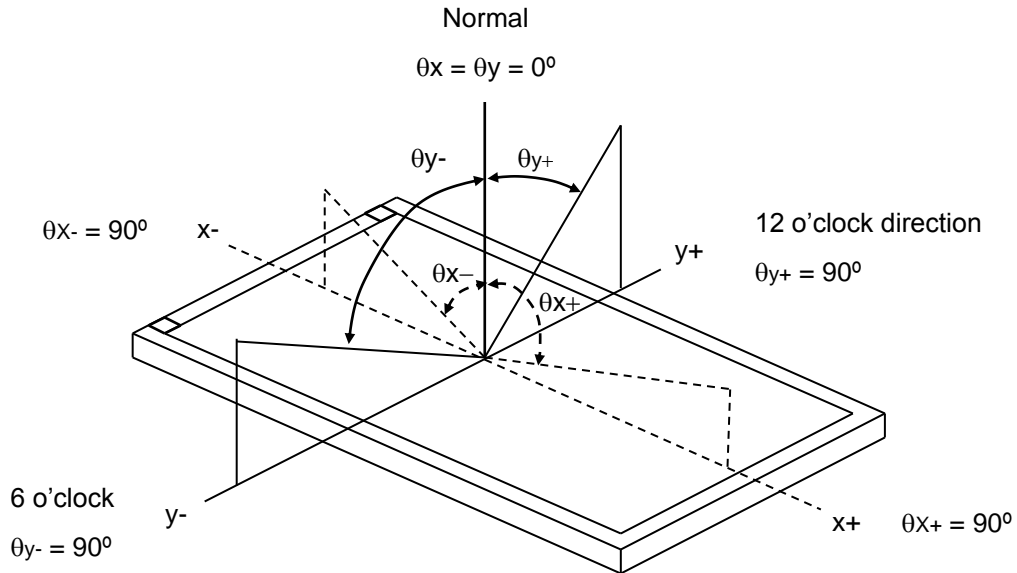

Note (2) Definition of Contrast Ratio (CR):

$$\text{Contrast ratio (CR)} = \frac{\text{Luminance measured when LCD on the "White" state}}{\text{Luminance measured when LCD on the "Black" state}}$$

Note (3) Definition of Response Time (T_R , T_F):

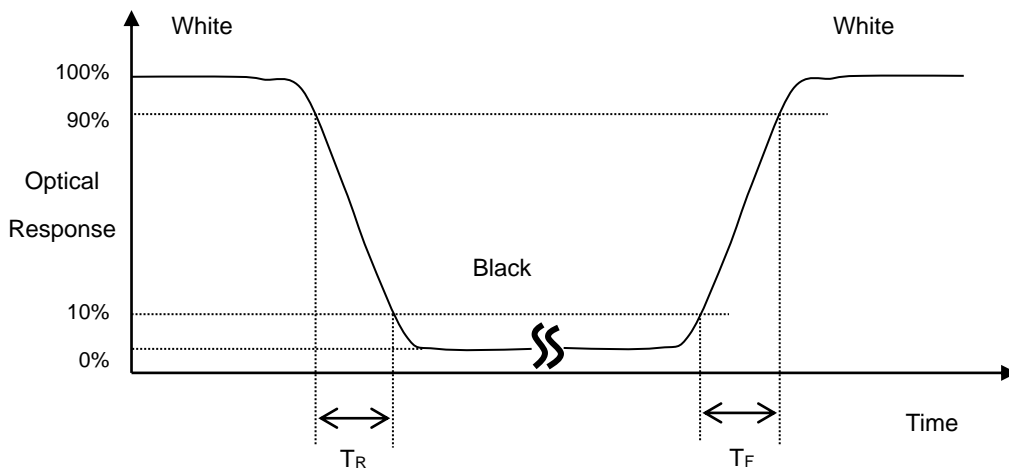



Note (4) Measurement Set-Up:

The LCD module should be stabilized at a given temperature for 30 minutes to avoid abrupt temperature change during measuring. In order to stabilize the luminance, the measurement should be executed after lighting Backlight for 30 minutes in a dark room or equivalent condition.

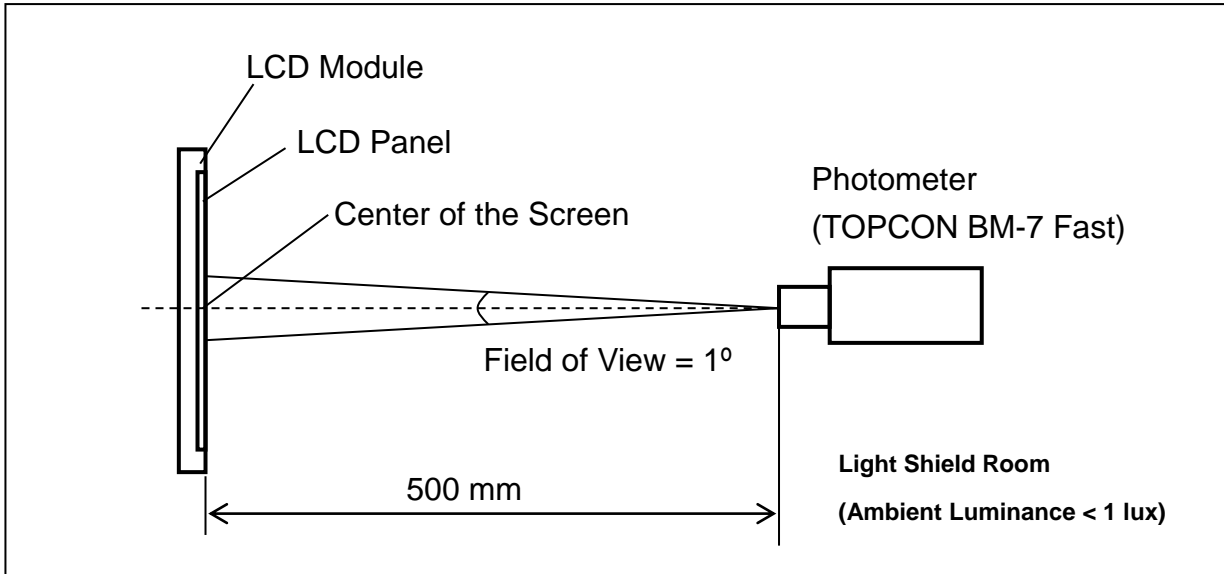

Note (5) Definition of White Variation (δW) :

Measure the luminance of gray level 255 at 5 points

$$\delta W = \text{Maximum} [L (1), L (2), L (3), L (4), L (5)] / \text{Minimum} [L (1), L (2), L (3), L (4), L (5)]$$

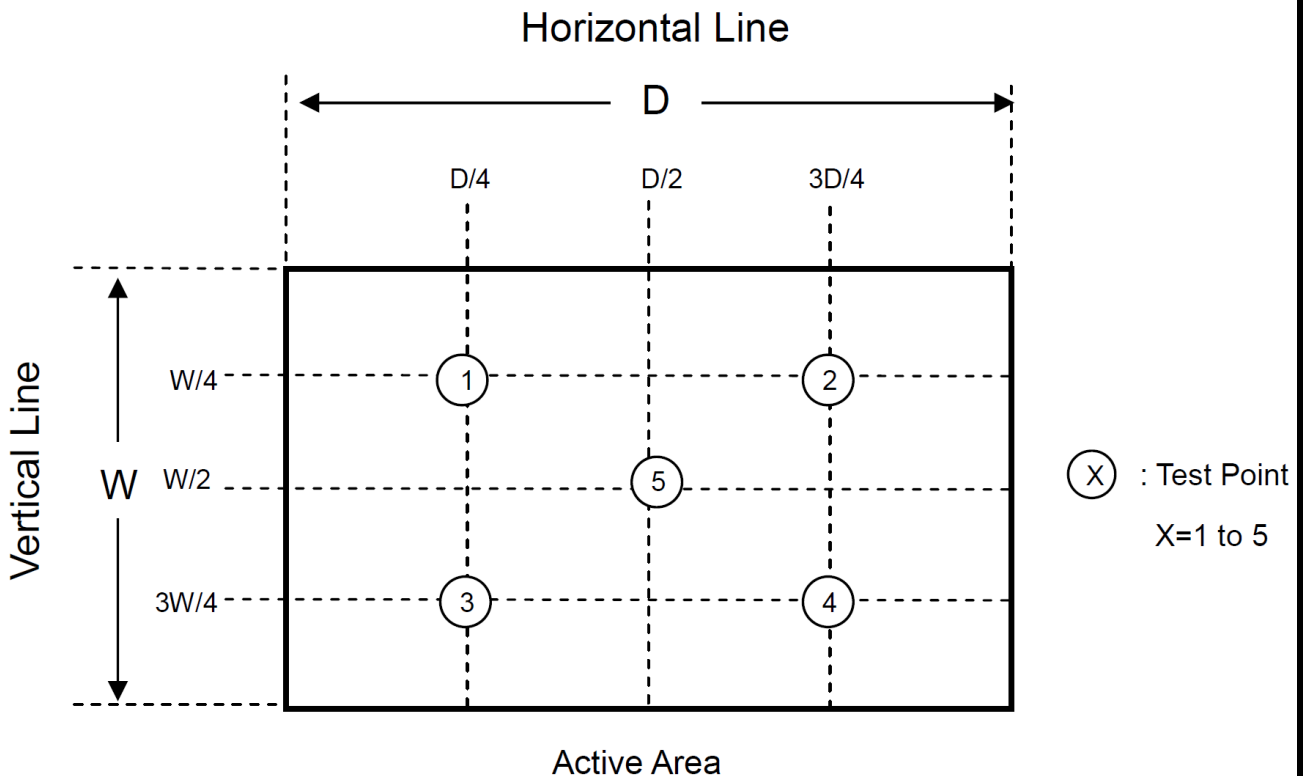



13. Reliability Test

Test Item	Test Condition	Note
High Temperature Storage Test	70°C, 240 hours	(1) (2)
Low Temperature Storage Test	-20°C, 240 hours	
Thermal Shock Storage Test	-20°C, 0.5hour↔70°C, 0.5hour, 100cycles, 1hour/cycle	
High Temperature Operation Test	70°C, 240 hours	
Low Temperature Operation Test	-20°C, 240 hours	
High Temperature & High Humidity Operation Test	60°C, 90%RH, 240hours	
Shock (Non-Operating)	200G, 2ms, half sine wave, 1 time for ± X, ± Y, ± Z.	
Vibration (Non-Operating)	1.5G, 10 ~ 300 Hz, 10min/cycle, 3 cycles each X, Y, Z	(3)

Note (1) There should be no condensation on the surface of panel during test.

Note (2) Temperature of panel display surface area should be 70 °C Max.

Note (3) At testing Vibration and Shock, the fixture in holding the module has to be hard and rigid enough so that the module would not be twisted or bent by the fixture.



14. Packaging

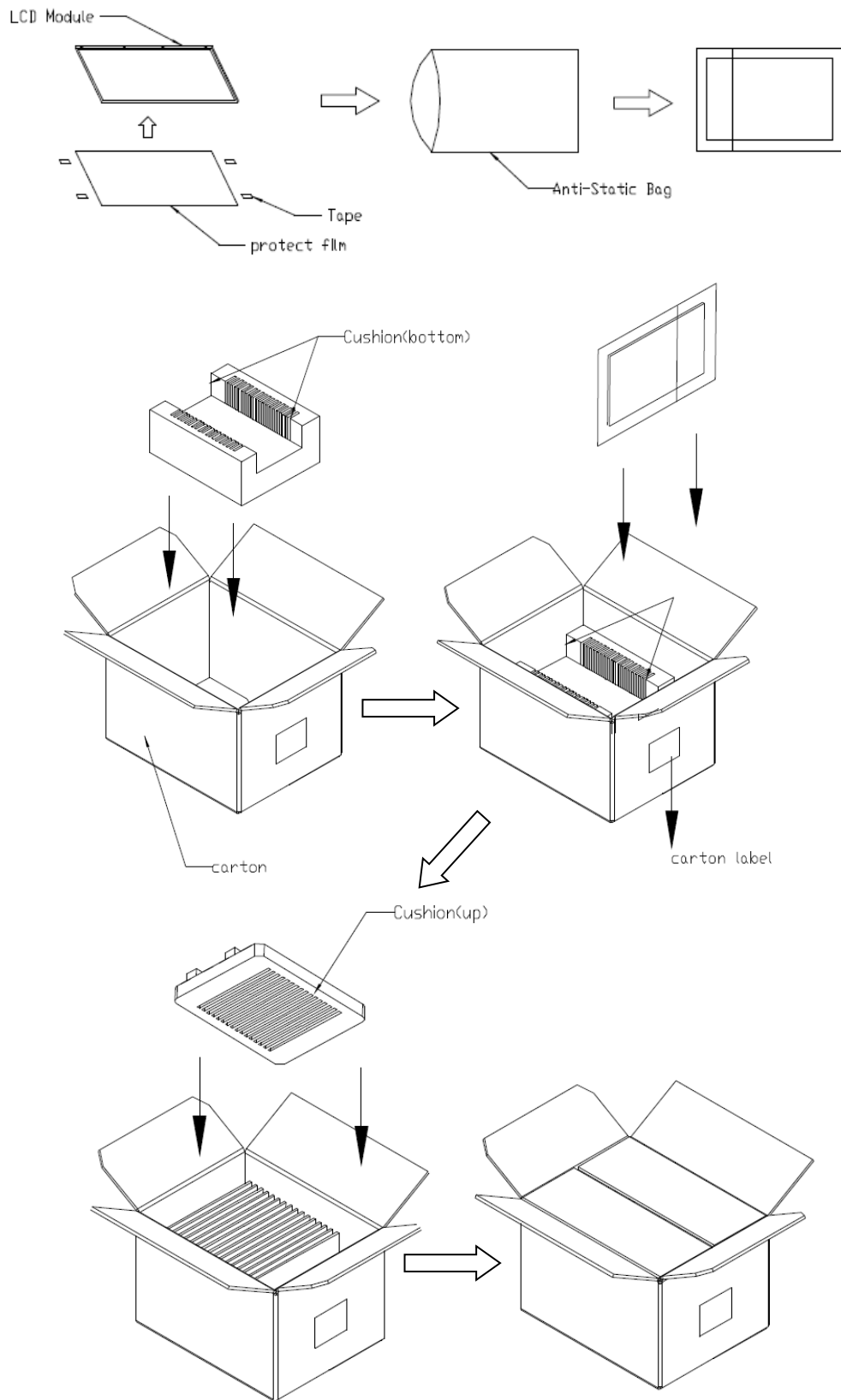

(1) 18pcs Modules/1 box

(2) Carton dimensions : 465(L)x362(W)x314(H)mm



15. Precautions

15.1 Assembly and Handling Precautions

- (1) Do not apply rough force such as bending or twisting to the module during assembly.
- (2) It's recommended to assemble or to install a module into the user's system in clean working areas. The dust and oil may cause electrical short or worsen the polarizer.
- (3) Don't apply pressure or impulse to the module to prevent the damage of LCD panel and Backlight.
- (4) Always follow the correct power-on sequence when the LCD module is turned on. This can prevent the damage and latch-up of the CMOS LSI chips.
- (5) Do not plug in or pull out the I/F connector while the module is in operation.
- (6) Do not disassemble the module.
- (7) Use a soft dry cloth without chemicals for cleaning, because the surface of polarizer is very soft and easily scratched.
- (8) Moisture can easily penetrate into LCD module and may cause the damage during operation.
- (9) High temperature or humidity may deteriorate the performance of LCD module. Please store LCD module in the specified storage conditions.
- (10) When ambient temperature is lower than 10°C, the display quality might be reduced. For example, the response time will become slow.

15.2 Safety Precautions

- (1) If the liquid crystal material leaks from the panel, it should be kept away from the eyes or mouth. In case of contact with hands, skin or clothes, it has to be washed away thoroughly with soap.
- (2) After the module's end of life, it is not harmful in case of normal operation and storage.

15.3 Terms of Warrant

- (1) Acceptance inspection period

The period is within one month after the arrival of contracted commodity at the buyer's factory site.

- (2) Applicable warrant period

The period is within twelve months since the date of shipping out under normal using and storage conditions.



P-TEC

MODEL NO.

PAGE

PT1076104A-MLMWF-EC03

SPEC &
SAMPLE

24

15.4 Caution

This P-TEC LCD module has been specifically designed for use only in electronic devices in the areas of audio control, office automation, industrial control, home appliances, etc. The modules should not be used in applications where module failure could result in physical harm or loss of life, and P-TEC expressly disclaims any and all liability relating in any way to the use of the module in such applications.



17. Definition of Labels

The bar code nameplate is pasted on each module as illustration, and its definitions are as following explanation.



- (a) Module Name : PT1076104A-MLMWF-EC03
- (b) Serial ID :

A B C D E F G H I J K L

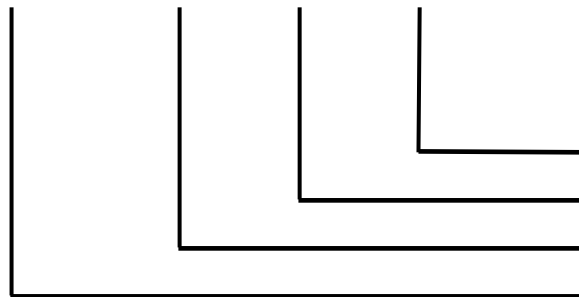

Serial No.
Factory Code
Manufactured Date
Screen Size

Serial ID includes the information as below :

- (a) Screen size (Diagonal) : Inch Code (ABCD)
3.5" → 0350
10.4" → 1040
- (b) Manufactured Date : Year, Month, Day (EFG)

Year (E)

Year	2000	2001	2002	2003	2004	2005	2006	2007	2008	2009
Mark	0	1	2	3	4	5	6	7	8	9
Year	2010	2011	2012	2013	2014	2015	2016	2017	2018	2019
Mark	A	B	C	D	E	F	G	H	I	J



Month (F)

Month	Jan.	Feb.	Mar.	Apr.	May	Jun.	Jul.	Aug.	Sep.	Oct.	Nov.	Dec.
Mark	1	2	3	4	5	6	7	8	9	A	B	C

Day (G)

Day	1	2	3	4	5	6	7	8	9	10	11	12	13	14	15	16
Mark	1	2	3	4	5	6	7	8	9	A	B	C	D	E	F	G
Day	17	18	19	20	21	22	23	24	25	26	27	28	29	30	31	
Mark	H	I	J	K	L	M	N	O	P	Q	R	S	T	U	V	

(c) Factory Code (H) :

For P-TEC internal use.

(d) Serial No. (IJKL) :

Manufacturing sequence of product, for example : 0001~9999.



18. Incoming Inspection Standards

18.1 The environmental condition of inspection

1. Description

These inspection standards shall be applied to LCD Module supplied by P-TEC ELECTRONICS LTD.

2. The environmental condition of inspection

The environmental condition and visual inspection shall be conducted as below.

- (1) Ambient temperature_15~25°C
- (2) Humidity_25~75 %RH
- (3) External appearance inspection shall be conducted by using a single 20W fluorescent lamp or equivalent illumination.
- (4) Panel visual inspection on the operation condition for cosmetic shall be conducted at the Distance 35cm or more between the LCD module and eyes of inspector.
Ambient Illumination_300 ~ 500 Lux for external appearance inspection
Ambient Illumination_100 ~ 200 Lux for light on inspection
- (5) The viewing angle_
 - a) 15 degree to the front surface of display panel in vertical direction.
 - b) 45 degree to the front surface of display panel in horizontal direction.
- (6) ND filter shall be conducted at the distance 2 cm to front surface of display panel and shall be conducted at the distance 35 cm between the LCD module and eyes of inspector.

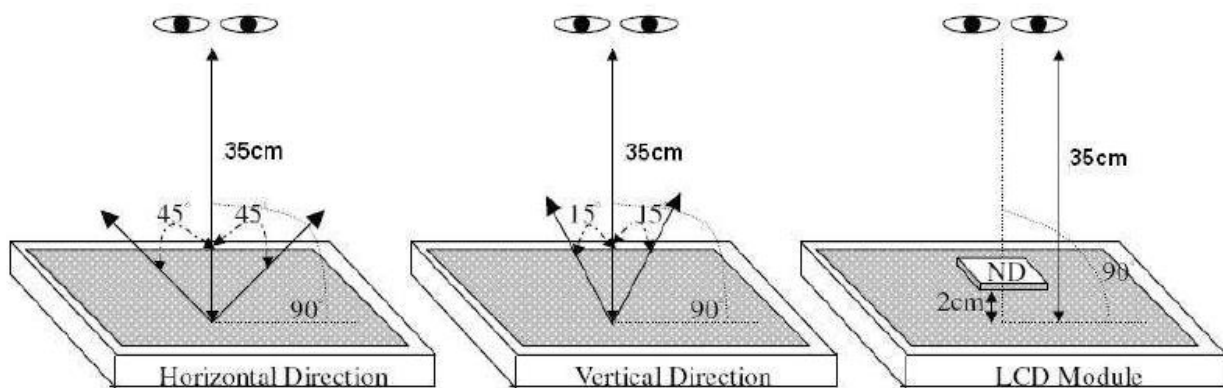



3. Classification of defects

Defects are classified two types, major defect and minor defect according to the defect. And, the definition of defects is classified as below.

(1) Major defect

Any defect may result in functional failure, or reduce the usability of product for its purpose. For example, electrical failure, deformation and etc..

(2) Minor defect

A defect that is not to reduce the usability of product for its intended purpose and un-uniformity, dot defect and etc..

The criteria on major or minor judgment will be according with the classification of defects.

4. Inspection Criteria

(1) Definition of dot defect induced from the panel inside

- a) Bright dot : Dots appear bright and unchanged in size in which module is displaying under black pattern.
- b) Dark dot : Dots appear dark and unchanged in size in which module is displaying under pure red, green, blue, white picture.
- c) 2 Full dot adjacent = 1pair.

Picture :

(a) Full dot



(b) 2 Full dot adjacent



(c) Spot defect





(2) Display Inspection standards

Items		Acceptable count
Full Bright dot	Random	$N \leq 3$
	2 dots adjacent	$N \leq 1$
	3 dots adjacent or more	$N \leq 0$
Full Dark dot	Random	$N \leq 5$
	2 dots adjacent	$N \leq 1$
	3 dots adjacent or more	$N \leq 0$
Total Full Bright and Full Dark dot		$N \leq 5$
Distance	Minimum Distance Between Full Bright dots	$L \geq 10\text{mm}$
	Minimum Distance Between Full Dark dots	$L \geq 10\text{mm}$
Display failure (V-line/H-line/Cross line etc.)		Not allowable
Mura	Not visible through 6% ND filter in 50% gray or judge by limit sample if necessary	

(3) Appearance inspection

Item	Standards
Foreign Black/White/Bright Spot	$D \leq 0.15\text{mm}$, Ignore $0.15 < D \leq 0.5 \text{ mm}$, $N \leq 4$
Foreign Black/White/Bright Lint	$W \leq 0.05\text{mm}$, Ignore $0.05 < W \leq 0.1 \text{ mm}$, $0.3 < L \leq 2.0 \text{ mm}$, $N \leq 4$
Polarizer Scratches	$W \leq 0.05\text{mm}$, Ignore $0.05 < W \leq 0.1 \text{ mm}$, $0.3 < L \leq 10.0 \text{ mm}$, $N \leq 4$
Dent/Air Bubble	Avg. $0.15 < D \leq 0.5 \text{ mm}$, $N \leq 4$

Note.1

$$D = (a+b)/2$$

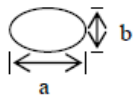

Note.2

W: width, L : length

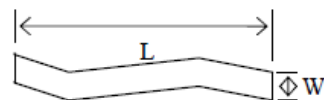

**5.External Appearance Inspection Criteria**

Item	Contents	
Screw	Parts mounting, incomplete assembly, deformation, oxidized, crooked or rusty is not permitted.	
CCFT cable	Cable not continuous 、 Break-off 、 Connector Burn-off /Break-off	
Metal frame (Bezel)	Scratch	*Noticeable scratch and exfoliation coating are not permitted. *The oxidized metal is not permitted.
	Incomplete assembly is not permitted.	
Backlight	Scratch	The scratch which may causes a problem in practical use is not permitted.
	Break-off	Breaking off is not permitted.
	Crack	The crack is not permitted.
Stain on Polarizer	The stain, which can't be wiped off, is not permitted.	
Tape/Label	Incorrect position, missed label is not permitted.	
Connector	Oxidized/rusty connector is not permitted.	
Outline size	Spec. out is not permitted.	

6.Classification of defects

Inspection Item	Criteria and Description	Defect type
Vertical line	Signal input, vertical line off or irregular V-line appears	major
Horizontal line	Signal input, horizontal line off or irregular H-line appears	major
Cross line	Pattern signal input, a correct display is not obtained	major
No display	Signal input, display is dead	major
Irregular display	Pattern signal input, a correct display is not obtained	major
Dots defect	Exceed specified standards	minor
Scratch and Dent on polarizer	Exceed specified standards	minor
Foreign material	Exceed specified standards	minor
Mura	Not visible through 6% ND filter in 50% gray pattern. or judge by limit sample	minor
Polarizer bubble	Exceed specified standards	minor



Incoming Inspection Touch Panel

Circular Defects
Linear Defects
Scratch
Air Bubble
Crack

(1) Circular Defects

$$\phi = (L+W)/2$$

Diameter(mm)	Spec
$\phi \leq 0.2$	No quantity limit
$0.2 < \phi < 0.5$	Max 5 defect
$0.5 \leq \phi$	Reject
The Min distance of defects must be above 10.0mm.	

(2) Linear Defects

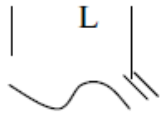

Length	Width	Acceptable
$12.0 \geq L$	$0.06 \geq W$	Accept
$L \geq 12.0$	$W \geq 0.06$	Reject

(3) Scratch

Length	Width	Acceptable
$12.0 \geq L$	$0.06 \geq W$	Accept
$L \geq 12.0$	$W \geq 0.06$	Reject
The Min distance of defects must be above 15.0mm.		

(4) Air Bubble

Diameter(mm)	Spec
$\phi \leq 0.2$	No quantity limit
$0.2 < \phi \leq 0.6$	Max 5 defect
The Min distance of defects must be above 10.0mm.	

(5) Crack

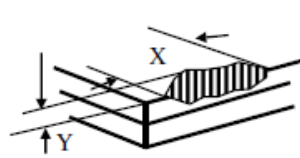

$$Z \leq T, X \leq 1/8 \text{ Sensor wide}$$

(Accept)

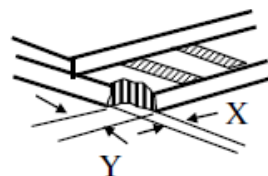

$$X \leq 3\text{mm and } Y \leq 1/3D$$

$$X \leq 1\text{mm}$$

(Reject)

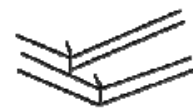

(Reject)

**18.2 Handling of LCM**

- (1) Don't give external shock.
- (2) Don't apply excessive force on the surface.
- (3) Liquid in LCD is hazardous substance. Must not lick and swallow. when the liquid is attach to your hand, skin, cloth etc. Wash it out thoroughly and immediately.
- (4) Don't operate it above the absolute maximum rating.
- (5) Don't disassemble the LCM.