



PRODUCT SPECIFICATION

Part Number

PT322435B-TLMWD-ER30

CUSTOMER	
CUSTOMER PART NUMBER	
DESCRIPTION	
APPROVED BY	
DATE	

**P-TEC****MODEL NO.**

PT322435B-TLMWD-ER30

SPEC SAMPLE

PAGE

2

1. Table of Contents

No.	Contents	Page
1	Table of Contents	2
2	Record of Revisions	3
3	Module Numbering System	4
4	Application	5
5	Features	5
6	General Specifications	5
7	Absolute Maximum Ratings	6
8	Electrical Characteristics	7
9	Block Diagram	10
10	Input / Output Terminals Pin Assignment	11
11	Interface Timing	15
12	Instruction Description	19
13	Optical Characteristics	20
14	Reliability Test	23
15	Packaging	24
16	Precautions	25
17	Outline Drawing	27
18	Definition of Labels	28
19	Incoming Inspection Standards	30



P-TEC

MODEL NO.

PAGE

PT322435B-TLMWD-ER30

SPEC SAMPLE

4

3. Module Numbering System

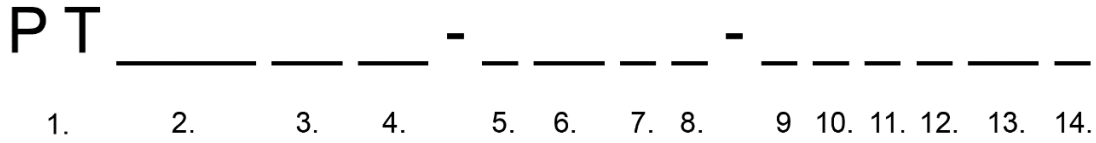

1. P-TEC TFT

8. VIEWING DIRECTION

D: 6 o'clock
U: 12 o'clock
F: Full Viewing Angle

2. LENGTH x WIDTH PIXELS

If third character is a zero, it is removed to shorten part number. Example: 240 x 320 = PT3224

9. A ~ Z CODE

Assigned by P-tec

3. DIAGONAL DIMENSIONS

Example: 3.5" display = 35 in part number

11. TEMPERATURE RANGE

Normal: Left Blank
Wide: X

4. PRODUCT VERSION

Series assigned by P-tec

12. LUMINANCE

Blank: Normal (<300 nit)
M: Middle (>= 300 nit)
H: High (> 600 nit)

5. LCD MODE

T: TN
I: IPS
V: VA

13. TOUCH PANEL OPTION

No TP: Left Blank
C: Capacitive TP
R: Resistive TP

6. POLARIZER

LM: Transmissive
LF: Transflective

14. SPECIAL CHARACTERS

Customer special requirements

7. BACKLIGHT COLOR

No Backlight: Left Blank
W: White
B: Blue/Green
S: Yellow/Green



4. Application

This specification is applied to the 3.5 inch QVGA supported TFT-LCD module With Transparent Touch Panel, and can display 262k colors. The module is designed for PMP, GPS, DMB, other electronic products which require flat panel display of digital signal interface, and used as the input devices for general electric appliances via both finger and pen-entry.

5. Features

- QVGA (320×240 pixels) resolution.
- Digital 24-bit RGB/SERIAL RGB/CCIR656+SPI
- Line inversion mode with stripe type.
- On-chip voltage generator
- SYNC mode is supported for digital RGB input data format.
- Transparent Touch panel
 - 4-Wire
 - Analog Resistive

6. General Specifications

Item	Specifications	Unit
Screen Size	3.5 (Diagonal)	inch
Display Format	320RGB(H)×240(V)	dot
Active Area	70.08(H)×52.56(V)	mm
Dot Pitch	0.073(H)×0.219(V)	mm
Pixel Configuration	RGB Vertical Stripe	-
Display Mode	TN Type Transmissive Mode Normally White	-
Surface Treatment	Anti-Glare	-
Viewing Direction	6 O'clock (The Gray Inversion will appear at this direction)	-
Outline Dimension	76.9(W)×63.9(H)×4.4(D)	mm
DC to DC circuit	Build-in	-
Weight	(41.5)	g
RoHS Compliance	P-tec certifies this product to be in compliance with European Union Directive 2002/95/EC on the restriction of certain hazardous substances in electrical and electronic equipment.	-



7. Absolute Maximum Ratings

7.1 Absolute Ratings of Environment

Item	Symbol	Value		Unit	Note
		Min.	Max.		
Storage Temperature	T _{ST}	-30	+80	°C	(1)
Operating Ambient Temperature	T _{OP}	-20	+70	°C	(1)

Note (1) Temperature and relative humidity range are shown in the figure below.

- (a) 90%RH Max. (Ta≤40°C).
- (b) Wet-bulb temperature should be 39°C Max. (Ta>40°C).
- (c) No condensation.

7.2 Electrical Absolute Ratings

7.2.1 TFT-LCD Module

(Ta=25±2°C, GND=V_{SS}=0V)

Item	Symbol	Value		Unit	Note
		Min.	Max.		
Digital Power Supply Voltage	V _{CC}	V _{SS} -0.3	5.0	V	-

7.2.2 Backlight Unit

(Ta=25±2°C)

Item	Symbol	Value		Unit	Note
		Min.	Max.		
Forward current	I _f	-	(30)	mA	(1)
Reverse voltage	V _r	-	(30)	V	(1)

Note (1) Permanent damage to the device may occur if maximum values are exceeded or reverse voltage is loaded.



8. Electrical Characteristics

8.1 TFT-LCD Module

(Ta=25±2°C)

Item	Symbol	Value			Unit	Note
		Min.	Typ.	Max.		
Digital Power Supply Voltage	V _{CC}	2.5	3.3	3.6	V	-
Input High Threshold Voltage	V _{IH}	0.8V _{CC}	-	V _{CC}	V	-
Input Low Threshold Voltage	V _{IL}	0	-	0.2V _{CC}	V	-

(GND=V_{SS}=0V)

Parameter	SYMBOL	Condition	Min	Typ	Max	Unit	Remarks
Digital Current	I _{VCC}	V _{CC} = 3.3V	-	8.6	12.04	mA	(1) (2)
Total Power Consumption	PC	V _{CC} = 3.3V	-	28.38	39.73	mW	(1) (2)

Note (1) The specified power consumption is under the conditions at V_{CC}=3.3V, F_V=60Hz, whereas a power dissipation check pattern below is displayed.

Note (2) Digital Parallel RGB interface.

Black Pattern / 0 Gray

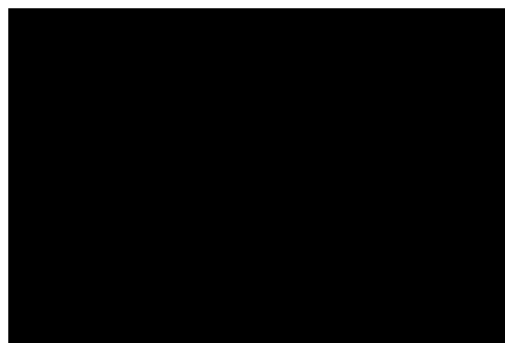

Active Area



8.2 Backlight Unit

(Ta=25±2°C)

Item	Symbol	Value			Unit	Note
		Min.	Typ.	Max.		
LED Voltage	VL	-	(19.5)	-	V	(1)
LED Current	IL	-	(20)	-	mA	(1)
Power Consumption	P _{BL}	-	(390)	-	mW	(1)
LED Life Time(25°C)	-	10000	-	-	hr	(2)

Note (1) The driving design of backlight unit is dependent on serial consideration of six LEDs.

Note (2) LED life time is defined as under 25±2°C , when the average brightness decrease to 50% of original brightness

8.3 Transparent Touch panel

Item		Value			Unit	Note
		Min.	Typ.	Max.		
Operating Voltage		-	5	-	V	-
Terminal Resistance	X-direction	300	-	900	Ω	At connector
	Y-direction	300	-	700	Ω	At connector
Insulation Resistance		≧ 20MΩ				at DC25V
Chatting		≦ 10 ms				-
Linearity		≦ 1.5%				(1)

Note(1): Measurement condition of Linearity

Linearity Definition

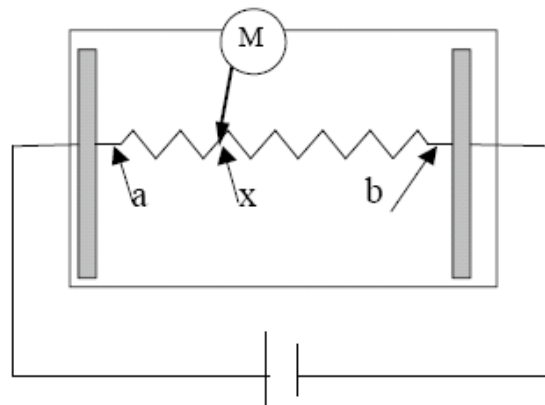

V_a : maximum voltage in the active area of touch panel

V_b: minimum voltage in the active area of touch panel

X : random measuring point

V_{xm}: Actual voltage of L_x point

V_{xi} : Theoretical voltage of L_x point

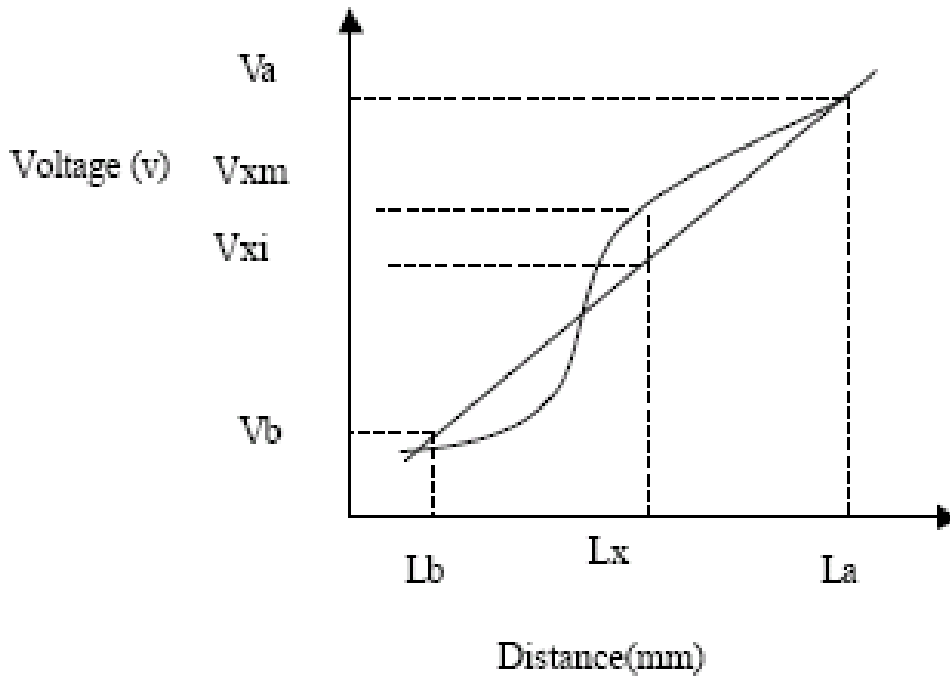

$$\text{Linearity} : [\frac{1}{2}V_{xi} - V_{xm} \frac{1}{2}] / (V_a - V_b) * 100\%$$

8.4 Mechanical & Reliability Characteristics

Items	Value		Note
Operation force	60-100g		(1)
Operation life	Pen sliding durability	100,000 times(min.)	(2)
	Tapping durability	1,000,000 times(min.)	(3)
Hardness	≥3H		JIS K5400, ASTM D3363

Note :

1. Stylus pen Input : R2.0mm polyacetal pen or Finger

2. Measurement for Surface area

-100,000 times or over

-Writing with R2.0mm plastic stylus pen ; writing force 250g in active area.

-Speed is 2/seconds frequency the same position(10~100mm) by R2.0mm polyacetal pen.(each direction inside Active area 3 mm).

3. 1,000,000 times or over (No damage on film surface)

-Pen : point with R2.0mm Silicon rubber

-Load : 250 g

-frequency : 2 times/s frequency

-Measurement position : 1 point of touch penal active area

Repeated; over 1,000,000 times



9. Block Diagram

TFT-LCD Module with Backlight Unit

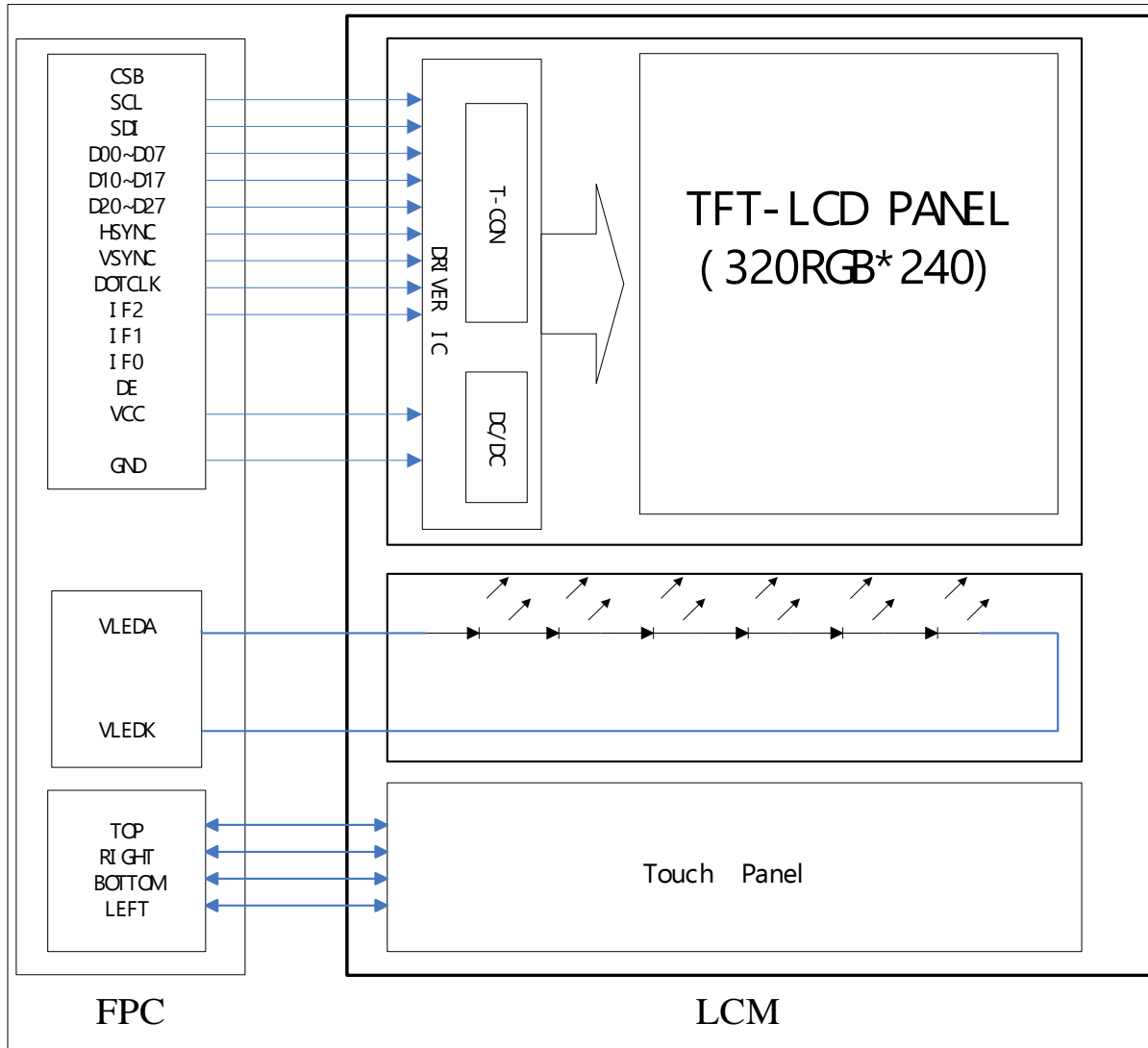

**10. Input / Output Terminals Pin Assignment****10.1 TFT-LCD Module**

Pin No.	Symbol	I/O	Description	Remark
1	LED_K	I	LED_cathode	
2	LED_K	I	LED_cathode	
3	LED_A	I	LED_anode	
4	LED_A	I	LED_anode	
5	Y2	I	Y_Up	
6	X1	I	X_Right	
7	NC	I	No connection	
8	RESET	I	Reset	
9	CSB	I	CHIP SELECT	Note 2
10	SCL	I	Serial Clock	Note 2
11	SDI	I	Serial Data	Note 2
12	D20	I	Blue data(LSB)	
13	D21	I	Blue data	
14	D22	I	Blue data	
15	D23	I	Blue data	
16	D24	I	Blue data	
17	D25	I	Blue data	
18	D26	I	Blue data	
19	D27	I	Blue data(MSB)	
20	D10	I	Green data(LSB)	
21	D11	I	Green data	
22	D12	I	Green data	
23	D13	I	Green data	
24	D14	I	Green data	
25	D15	I	Green data	
26	D16	I	Green data	
27	D17	I	Green data(MSB)	
28	D00	I	Red data(LSB)	Note 3
29	D01	I	Red data	Note 3
30	D02	I	Red data	Note 3
31	D03	I	Red data	Note 3
32	D04	I	Red data	Note 3



Pin No.	Symbol	I/O	Description	Remark
33	D05	I	Red data	Note 3
34	D06	I	Red data	Note 3
35	D07	I	Red data(MSB)	Note 3
36	HSYNC	I	Horizontal synchronous signal	
37	VSYNC	I	Vertical synchronous signal	
38	DOTCLK	I	Data Colck	
39	NC	I	No connection	
40	NC	I	No connection	
41	V _{CC}	I	Vdigital	
42	V _{CC}	I	Vdigital	
43	Y1	I	Y_Bottom	
44	X2	I	X_Left	
45	NC	I	No connection	
46	NC	I	No connection	
47	NC	I	No connection	
48	IF2	I	Control the input data format	Note 4
49	IF1	I	Control the input data format	Note 4
50	IF0	I	Control the input data format	Note 4
51	NC	I	No connection	
52	DE	I	Data Enable Input	Note 1
53	GND	I	Ground	
54	GND	I	Ground	

Note:

- 1.For digital RGB input data format, both SYNC mode and DE+SYNC mode are supported.
If DE signal is pull high or floating, SYNC mode is used. Otherwise, DE+SYNC mode is used. Suggest used SYNC mode!! Suggest the DE signal usually pull high or floating.
- 2.usually pull high.
- 3.IF select serial RGB or CCIR656 input mode is selected, only D00-D07 used, and the other short to GND or floating, Only selected serial RGB/CCIR656 interface,D0X BUS will enable, Digital input mode D00 is LSB and D07 is MSB.
4. Control the input data format



P-TEC

MODEL NO.

PAGE

PT322435B-TLMWD-ER30

SPEC SAMPLE

13

IF2	IF1	IF0	Format	Operating frequency
0	0	0	Parallel-RGB data format	6.5MHz
0	1	0	Serial-RGB data format	19.5MHz
1	0	0	CCIR 656 data format (640RGB)	24.54MHz
1	1	0	CCIR 656 data format (720RGB)	27MHz

Mode	D[7:0]	D[15:8]	D[23:16]	IHS	IVS	DEN
ITU-R BT 656	D[7:0]	GND	GND	NC	NC	NC
8 bit RGB	D[7:0]	GND	GND	IHS	IVS	NC for HV Mode
						DEN for DEN Mode
24 bit RGB	R[7:0]	G[7:0]	B[7:0]	IHS	IVS	NC for HV Mode
						DEN for DEN Mode



10.2 Color Data Input Assignment

The brightness of each primary color(red, green and blue) is based on the 8 bit gray scale data input for the color. The higher the binary input, the brighter the color. The table provides the assignment of color versus data input.

Color	Data Signal																							
	Red								Green								Blue							
	D07	D06	D05	D04	D03	D02	D01	D00	D17	D16	D15	D14	D13	D12	D11	D10	D27	D26	D25	D24	D23	D22	D21	D20
Basic Colors	Black	0	0	0	0	0	0	0	0	0	0	0	0	0	0	0	0	0	0	0	0	0	0	0
	Red	1	1	1	1	1	1	1	1	0	0	0	0	0	0	0	0	0	0	0	0	0	0	0
	Green	0	0	0	0	0	0	0	0	1	1	1	1	1	1	1	0	0	0	0	0	0	0	0
	Blue	0	0	0	0	0	0	0	0	0	0	0	0	0	0	0	1	1	1	1	1	1	1	1
	Cyan	0	0	0	0	0	0	0	0	1	1	1	1	1	1	1	1	1	1	1	1	1	1	1
	Magenta	1	1	1	1	1	1	1	1	0	0	0	0	0	0	0	1	1	1	1	1	1	1	1
	White	1	1	1	1	1	1	1	1	1	1	1	1	1	1	1	1	0	0	0	0	0	0	0
Gray Scale Of RED	Red(0) / Dark	0	0	0	0	0	0	0	0	0	0	0	0	0	0	0	0	0	0	0	0	0	0	
	Red(1)	0	0	0	0	0	0	0	1	0	0	0	0	0	0	0	0	0	0	0	0	0	0	
	Red(2)	0	0	0	0	0	0	1	0	0	0	0	0	0	0	0	0	0	0	0	0	0	0	
	:	:	:	:	:	:	:	:	:	:	:	:	:	:	:	:	:	:	:	:	:	:	:	
	:	:	:	:	:	:	:	:	:	:	:	:	:	:	:	:	:	:	:	:	:	:	:	
	Red(253)	1	1	1	1	1	1	0	1	0	0	0	0	0	0	0	0	0	0	0	0	0	0	
	Red(254)	1	1	1	1	1	1	1	0	0	0	0	0	0	0	0	0	0	0	0	0	0	0	
Red(255)	1	1	1	1	1	1	1	1	0	0	0	0	0	0	0	0	0	0	0	0	0	0		
Gray Scale Of Green	Green(0) / Dark	0	0	0	0	0	0	0	0	0	0	0	0	0	0	0	0	0	0	0	0	0	0	
	Green(1)	0	0	0	0	0	0	0	0	0	0	0	0	0	0	1	0	0	0	0	0	0	0	
	Green(2)	0	0	0	0	0	0	0	0	0	0	0	0	0	0	1	0	0	0	0	0	0	0	
	:	:	:	:	:	:	:	:	:	:	:	:	:	:	:	:	:	:	:	:	:	:	:	
	:	:	:	:	:	:	:	:	:	:	:	:	:	:	:	:	:	:	:	:	:	:	:	
	Green(253)	0	0	0	0	0	0	0	1	1	1	1	1	1	0	1	0	0	0	0	0	0	0	
	Green(254)	0	0	0	0	0	0	0	1	1	1	1	1	1	1	0	0	0	0	0	0	0	0	
Green(255)	0	0	0	0	0	0	0	1	1	1	1	1	1	1	1	0	0	0	0	0	0	0		
Gray Scale Of Blue	Blue(0) / Dark	0	0	0	0	0	0	0	0	0	0	0	0	0	0	0	0	0	0	0	0	0	0	
	Blue(1)	0	0	0	0	0	0	0	0	0	0	0	0	0	0	0	0	0	0	0	0	0	1	
	Blue(2)	0	0	0	0	0	0	0	0	0	0	0	0	0	0	0	0	0	0	0	0	0	1	
	:	:	:	:	:	:	:	:	:	:	:	:	:	:	:	:	:	:	:	:	:	:	:	
	:	:	:	:	:	:	:	:	:	:	:	:	:	:	:	:	:	:	:	:	:	:	:	
	Blue(253)	0	0	0	0	0	0	0	0	0	0	0	0	0	0	0	1	1	1	1	1	1	0	
	Blue(254)	0	0	0	0	0	0	0	0	0	0	0	0	0	0	0	1	1	1	1	1	1	1	
Blue(255)	0	0	0	0	0	0	0	0	0	0	0	0	0	0	0	1	1	1	1	1	1	1		

**11. Interface Timing****11.1 Input Signal Characteristics****11.1.1 Digital Parallel RGB Interface (960×240 resolution)**

Characteristics	Symbol	Min.	Typ.	Max.	Unit	
		24 bit	24 bit	24 bit		
DOTCLK Frequency	fDOTCLK	-	6.5	10	MHz	
DOTCLK Period	tDOTCLK	100	154	-	ns	
Horizontal Frequency (Line)	fH	-	14.9	22.35	KHz	
Vertical Frequency (Refresh)	fV	-	60	90	Hz	
Horizontal Back Porch	tHBP	-	68	-	tDOTCLK	
Horizontal Front Porch	tHFP	-	20	-	tDOTCLK	
Horizontal Data Start Point	tHBP	-	68	-	tDOTCLK	
Horizontal Blanking Period	tHBP + tHFP	-	88	-	tDOTCLK	
Horizontal Display Area	HDISP	-	320	-	tDOTCLK	
Horizontal Cycle	Hcycle	-	408	450	tDOTCLK	
Vertical Back Porch	tVBP	-	18	-	Lines	
Vertical Front Porch	tVFP	-	4	-	Lines	
Vertical Data Start Point	tVBP	-	18	-	Lines	
Vertical Blanking Period	tVBP + tVFP	-	22	-	Lines	
Vertical Display Area	NTSC	VDISP	-	240	-	Lines
	PAL		280(PALM=0)			
			288(PALM=1)			
Vertical Cycle	NTSC	Vcycle	-	262	350	Lines
	PAL		313			

11.1.2 CCIR656 Interface

Signal	Item	Symbol	Min	Typ	Max	Unit
Dotclk	Frequency	Tosc	-	37	-	ns
	High Time	Tch	-	78	-	ns
	Low Time	Tcl	-	78	-	ns
Data	Setup Time	Tsu	12	-	-	ns
	Hold Time	Thd	12	-	-	ns

11.1.3 SPI Interface

Characteristics	Symbol	Min.	Typ.	Max.	Unit
Serial Clock Frequency	fclk	-	-	20	MHz
Serial Clock Cycle Time	tclk	50	-	-	ns
Clock Low Width	tsl	25	-	-	ns
Clock High Width	tsh	25	-	-	ns
Clock Rising Time	trs	-	-	30	ns
Clock Falling Time	tfl	-	-	30	ns
Chip Select Setup Time	tcss	0	-	-	ns
Chip Select Hold Time	tcsh	10	-	-	ns
Chip Select High Delay Time	tcsd	20	-	-	ns
Data Setup Time	tds	5	-	-	ns
Data Hold Time	tdh	10	-	-	ns



11.2 Waveform

11.2.1 CLK, DATA and DE waveforms in Digital Serial RGB

- Digital Serial RGB

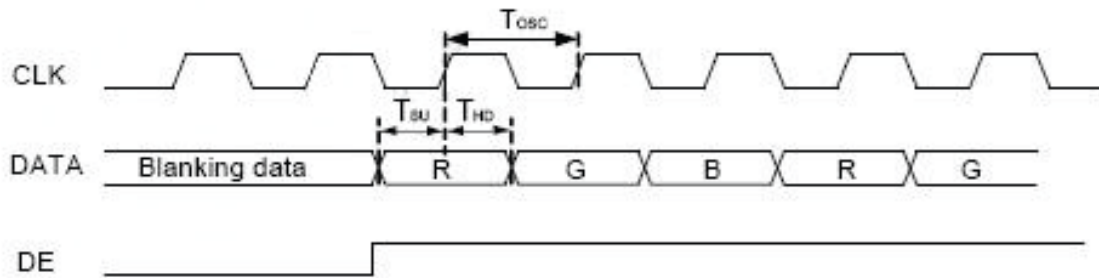

11.2.2 CLK, DATA and DE waveforms in Digital Parallel RGB

- Digital Parallel RGB

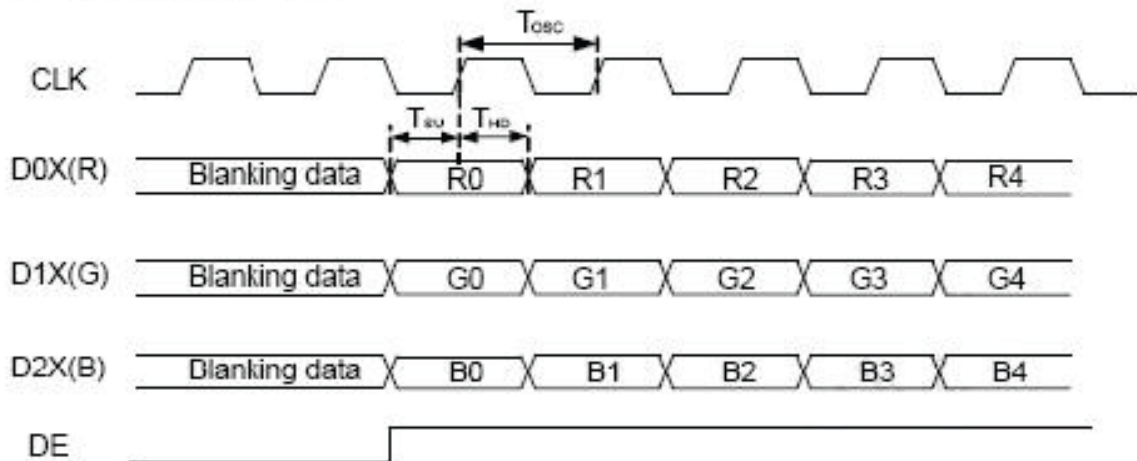



11.2.3 CLK and DATA waveforms in CCIR656

- CCIR656

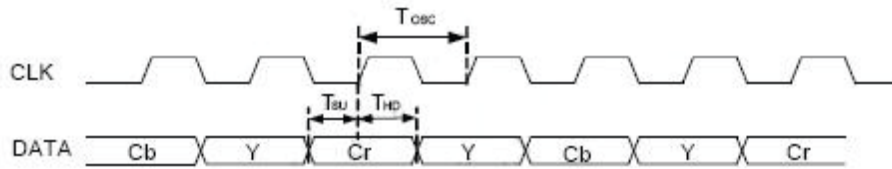

11.2.4 SPI

R/S	R/W	status
0	0	Write SPI address
1	0	Write SPI data

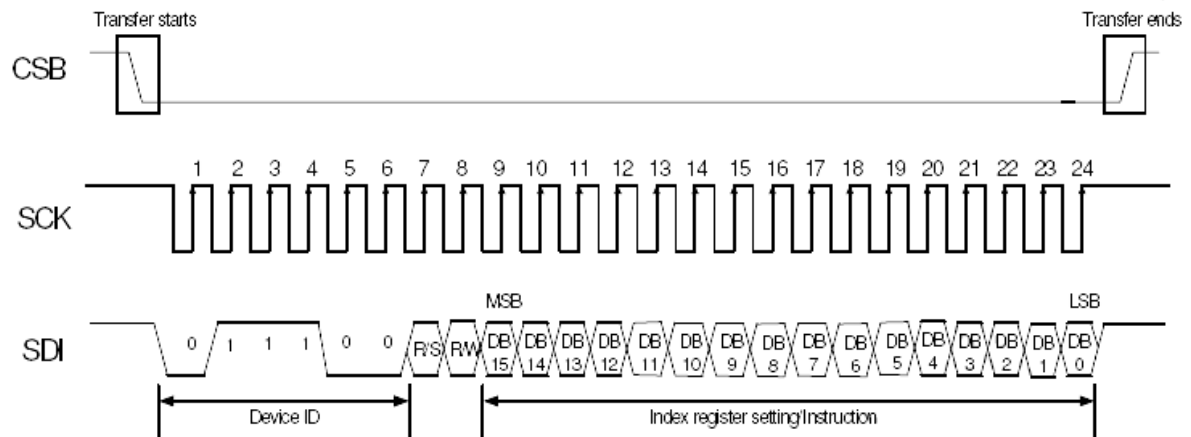



First Transmission (Register)

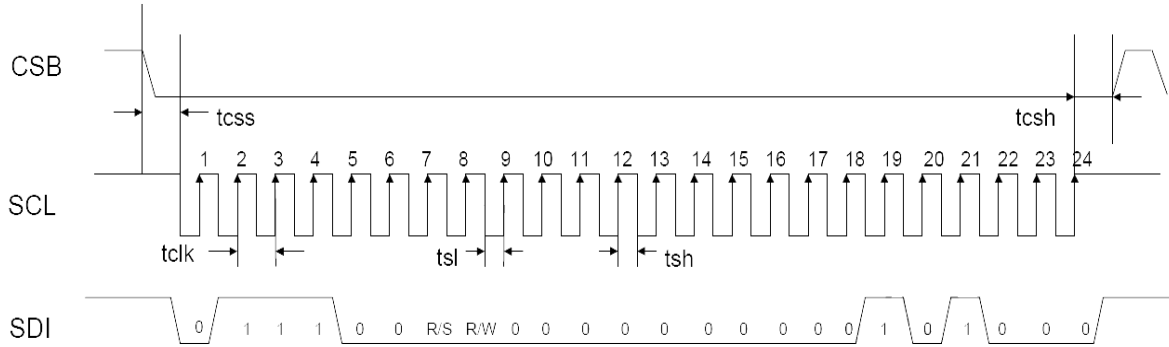

Second Transmission (Data)

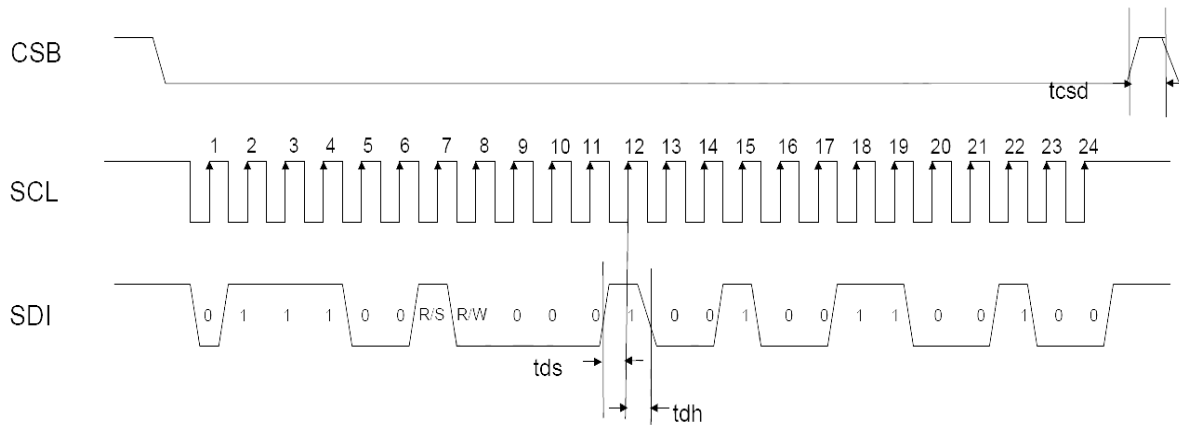

11.3 Power On / Off Sequence

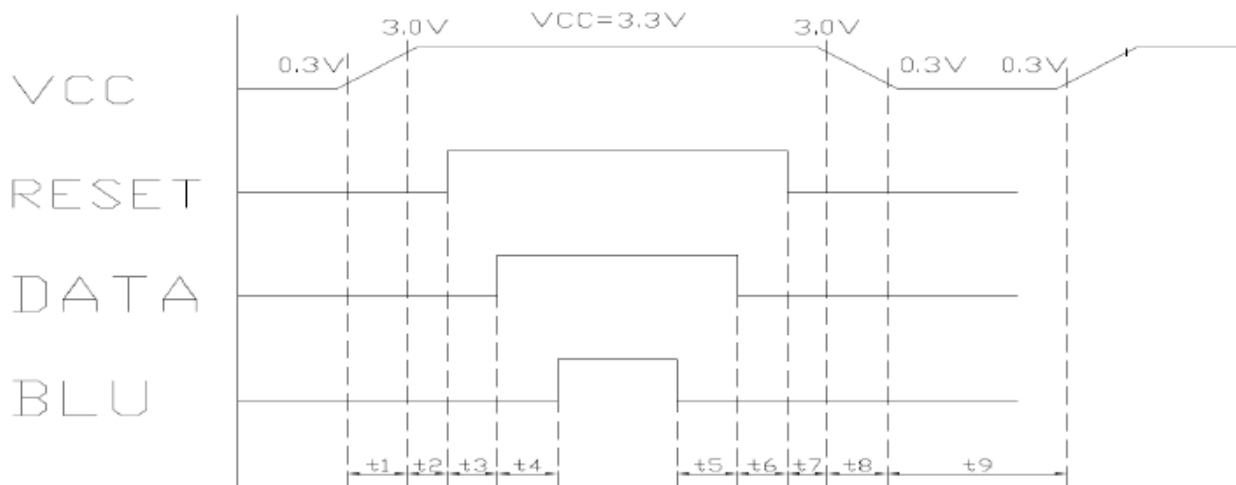

- T1 ≤ 10ms**
- 200ms ≤ T5**
- 1 sec ≤ T9**
- 10us ≤ T2**
- 50ms ≤ T6**
- 50ms ≤ T3**
- 10us ≤ T7**
- 200ms ≤ T4**
- T8 ≤ 10ms**



P-TEC

MODEL NO.

PT322435B-TLMWD-ER30

SPEC SAMPLE

PAGE

19

12. Instruction Description

SPI Command Table

Reg#	Register	R/W	R/S	IB15	IB14	IB13	IB12	IB11	IB10	IB9	IB8	IB7	IB6	IB5	IB4	IB3	IB2	IB1	IB0
SP	Status Read	1	0	L7	L6	L5	L4	L3	L2	L1	L0	0	0	0	0	0	0	0	0
R01h	Driver output control	0	1	0	RL	REV	PINV	BGR	SM	TB	CPE	0	0	0	0	0	0	0	0
R02h	LCD driver AC control	0	1	0	0	0	0	0	0	B/C	0	0	0	0	0	0	0	0	0
R03h	Power control (1)	0	1	DCT3	DCT2	DCT1	DCT0	BTF	BT2	BT1	BT0	DC3	DC2	DC1	DC0	AP2	AP1	AP0	0
R04h	Data and color filter control	0	1	0	0	0	0	0	PALM	BLT1	BLT0	OEA1	OEA0	SEL2	SEL1	SEL0	SWD2	SWD1	SWD0
R05h	Function control	0	1	GHN	XDK	GDIS	LPF	DEP	CKP	VSP	HSP	DEO	DIT	0	PWM	0	FB2	FB1	FB0
R06h	Reserved	Reserved																	
R07h	Reserved	Reserved																	
R0Ah	Contrast/Brightness control	0	1	0	BR6	BR5	BR4	BR3	BR2	BR1	BR0	0	0	0	CON4	CON3	CON2	CON1	CON0
R0Bh	Frame cycle control	0	1	NO1	NO0	SDT1	SDT0	0	EQ2	EQ1	EQ0	0	0	0	0	0	0	0	0
R0Dh	Power control (2)	0	1	0	VRC2	VRC1	VRC0	0	0	VDS1	VDS0	0	0	VRH5	VRH4	VRH3	VRH2	VRH1	VRH0
R0Eh	Power control (3)	0	1	0	0	1	VDV6	VDV5	VDV4	VDV3	VDV2	VDV1	VDV0	0	0	0	0	0	0
R0Fh	Gate scan starting Position	0	1	0	0	0	0	0	0	0	0	SCN7	SCN6	SCN5	SCN4	SCN3	SCN2	SCN1	SCN0
R16h	Horizontal Porch	0	1	XLIM8	XLIM7	XLIM6	XLIM5	XLIM4	XLIM3	XLIM2	XLIM1	XLIM0	0	0	0	0	0	0	0
R17h	Vertical Porch	0	1	STH1	STH0	HBP6	HBP5	HBP4	HBP3	HBP2	HBP1	HBP0	VBP6	VBP5	VBP4	VBP3	VBP2	VBP1	VBP0
R1Eh	Power control (4)	0	1	0	0	0	0	0	0	0	0	nOTP	VCM6	VCM5	VCM4	VCM3	VCM2	VCM1	VCM0
R27h	Reserved	Reserved																	
R28h	Reserved	Reserved																	
R29h	Reserved	Reserved																	
R2Bh	Reserved	Reserved																	
R30h	γ control (1)	0	1	0	0	0	0	0	PKP 12	PKP 11	PKP 10	0	0	0	0	0	PKP 02	PKP 01	PKP 00
R31h	γ control (2)	0	1	0	0	0	0	0	PKP 32	PKP 31	PKP 30	0	0	0	0	0	PKP 22	PKP 21	PKP 20
R32h	γ control (3)	0	1	0	0	0	0	0	PKP 52	PKP 51	PKP 50	0	0	0	0	0	PKP 42	PKP 41	PKP 40
R33h	γ control (4)	0	1	0	0	0	0	0	PRP 12	PRP 11	PRP 10	0	0	0	0	0	PRP 02	PRP 01	PRP 00
R34h	γ control (5)	0	1	0	0	0	0	0	PKN 12	PKN 11	PKN 10	0	0	0	0	0	PKN 02	PKN 01	PKN 00
R35h	γ control (6)	0	1	0	0	0	0	0	PKN 32	PKN 31	PKN 30	0	0	0	0	0	PKN 22	PKN 21	PKN 20
R36h	γ control (7)	0	1	0	0	0	0	0	PKN 52	PKN 51	PKN 50	0	0	0	0	0	PKN 42	PKN 41	PKN 40
R37h	γ control (8)	0	1	0	0	0	0	0	PRN 12	PRN 11	PRN 10	0	0	0	0	0	PRN 02	PRN 01	PRN 00
R3Ah	γ control (9)	0	1	0	0	0	VRP 14	VRP 13	VRP 12	VRP 11	VRP 10	0	0	0	0	VRP 03	VRP 02	VRP 01	VRP 00
R3Bh	γ control (10)	0	1	0	0	0	VRN 14	VRN 13	VRN 12	VRN 11	VRN 10	0	0	0	0	VRN 03	VRN 02	VRN 01	VRN 00

Note: * means don't care



13. Optical Characteristics

The optical characteristics should be measured in a dark environment (≤ 1 lux) or equivalent state with the methods shown in Note (4).

Item	Symbol	Conditions	Min.	Typ.	Max.	Unit	Note	
Contrast Ratio	CR	$\theta_x=0^\circ, \theta_y=0^\circ$ Viewing Normal Angle	150	(350)	-	-	(2)	
Response Time	T_{R+T_F}		-	50	-	ms	(3)	
Luminance(Center)	Y		260	(285)	-	cd/m ²	(4)	
Brightness uniformity	B _{UNI}		80	-	-	%	(5)	
Color Chromaticity	Red		R _x	0.566	0.616	0.666	-	(1),(4)
			R _y	0.293	0.343	0.393	-	
	Green		G _x	0.255	0.305	0.355	-	
			G _y	0.547	0.597	0.647	-	
	Blue		B _x	0.088	0.138	0.188	-	
			B _y	0.045	0.095	0.145	-	
	White	W _x	0.247	0.297	0.347	-		
		W _y	0.292	0.342	0.392	-		
Viewing Angle	Horizontal	θ_{x+}	55	(70)	-	deg.		
		θ_{x-}	55	(70)	-			
	Vertical	θ_{y+}	40	(55)	-			
		θ_{y-}	50	(70)	-			



Note (1) Definition of Viewing Angle (θ_x, θ_y):

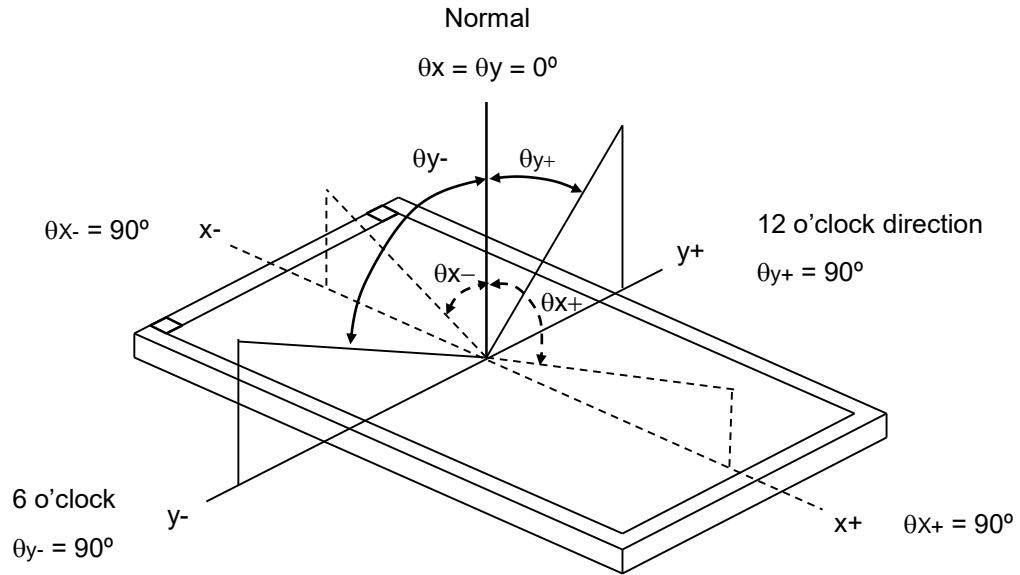

Note (2) Definition of Contrast Ratio (CR):

$$CR = \frac{\text{Luminance (brightness) all pixels "White"}}{\text{Luminance (brightness) all pixels "dark"}}$$

Note (3) Definition of Response Time (T_R, T_F):

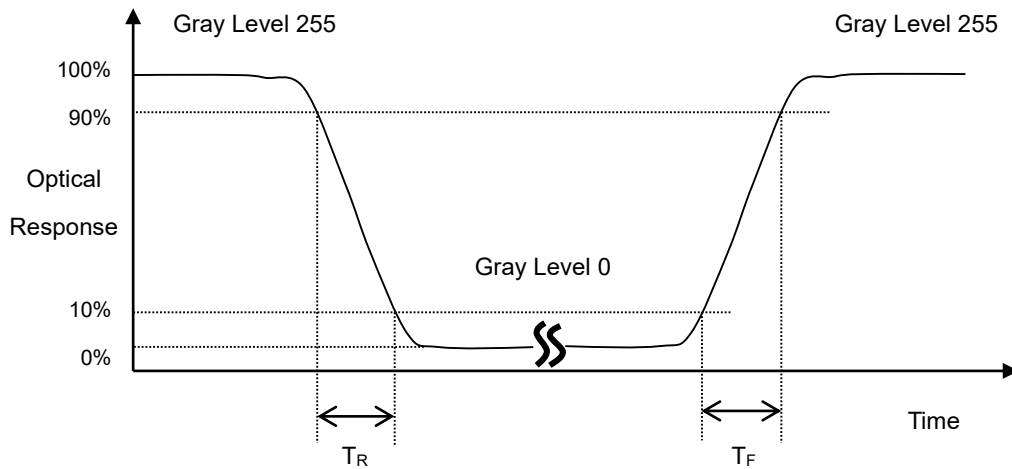



Note (4) Measurement Set-Up:

The LCD module should be stabilized at a given temperature for 30 minutes to avoid abrupt temperature change during measuring. In order to stabilize the luminance, the measurement should be executed after lighting Backlight for 30 minutes in a windless room.

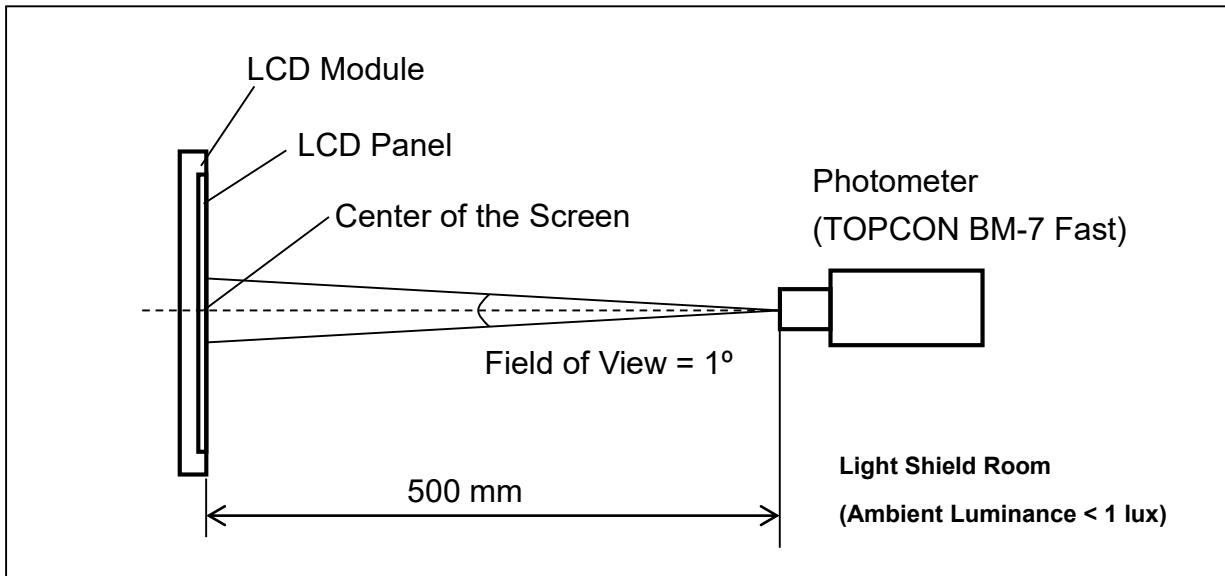

Note (5) Definition of brightness uniformity

$$\text{Brightness uniformity} = (\text{Min Luminance of 9 points}) / (\text{Max Luminance of 9 points}) \times 100\%$$

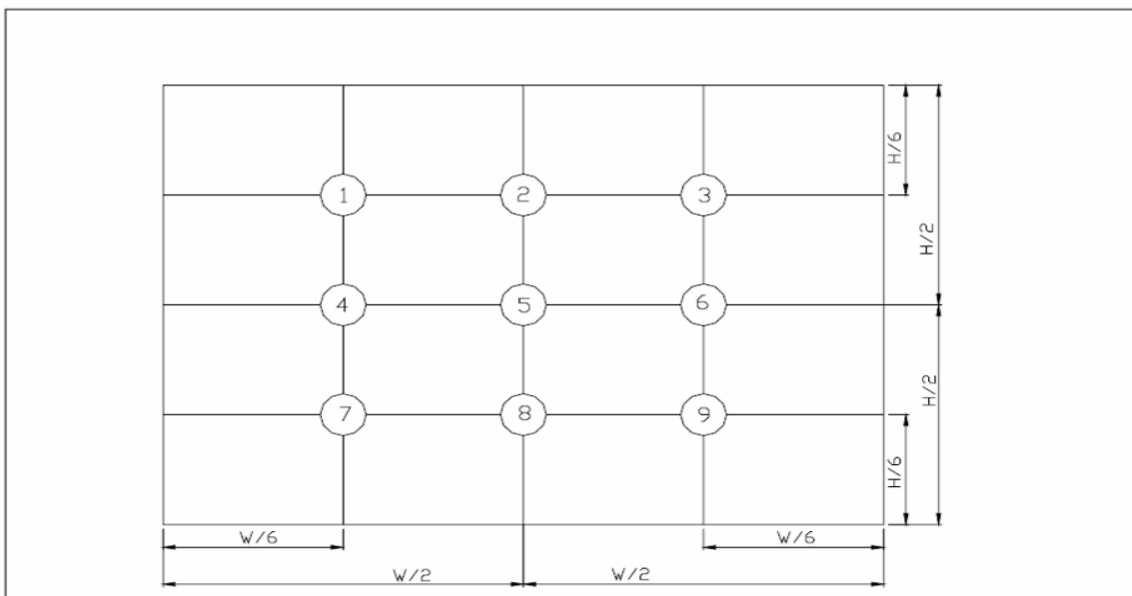

(單位 : mm)

**14. Reliability Test**

No.	Test Items	Test Condition	Remark
1	High Temperature Storage Test	T _a = 80°C 240 hours	-
2	Low Temperature Storage Test	T _a = -30°C 240 hours	-
3	High Temperature Operation Test	T _a = 70°C 240 hours	-
4	Low Temperature Operation Test	T _a = -20°C 240 hours	-
5	High Temperature and High Humidity Operation Test	T _a =60°C 90%RH 240 hours	-
6	Electro Static Discharge Test (non-operating)	-Panel Surface/Top Case : 150pF, 330Ω Air: ±15kV, Contact: ±8kV	-
7	Mechanical Shock Test (non-operating)	Half sine wave, 100G, 6ms 3 times shock of each six surfaces	-
8	Vibration Test (non-operating)	Sine wave, 10 ~ 55 ~ 10Hz, 3 axis, 2 hours/axis	-
9	Thermal Shock Test (non-operating)	-20°C(30min) ~ 70°C(30min),100 cycles	-
10	Drop Test(with Carton)	Height: 80cm 1 corner, 3 edges, 6 surfaces	-



15. Packaging

Packing Method

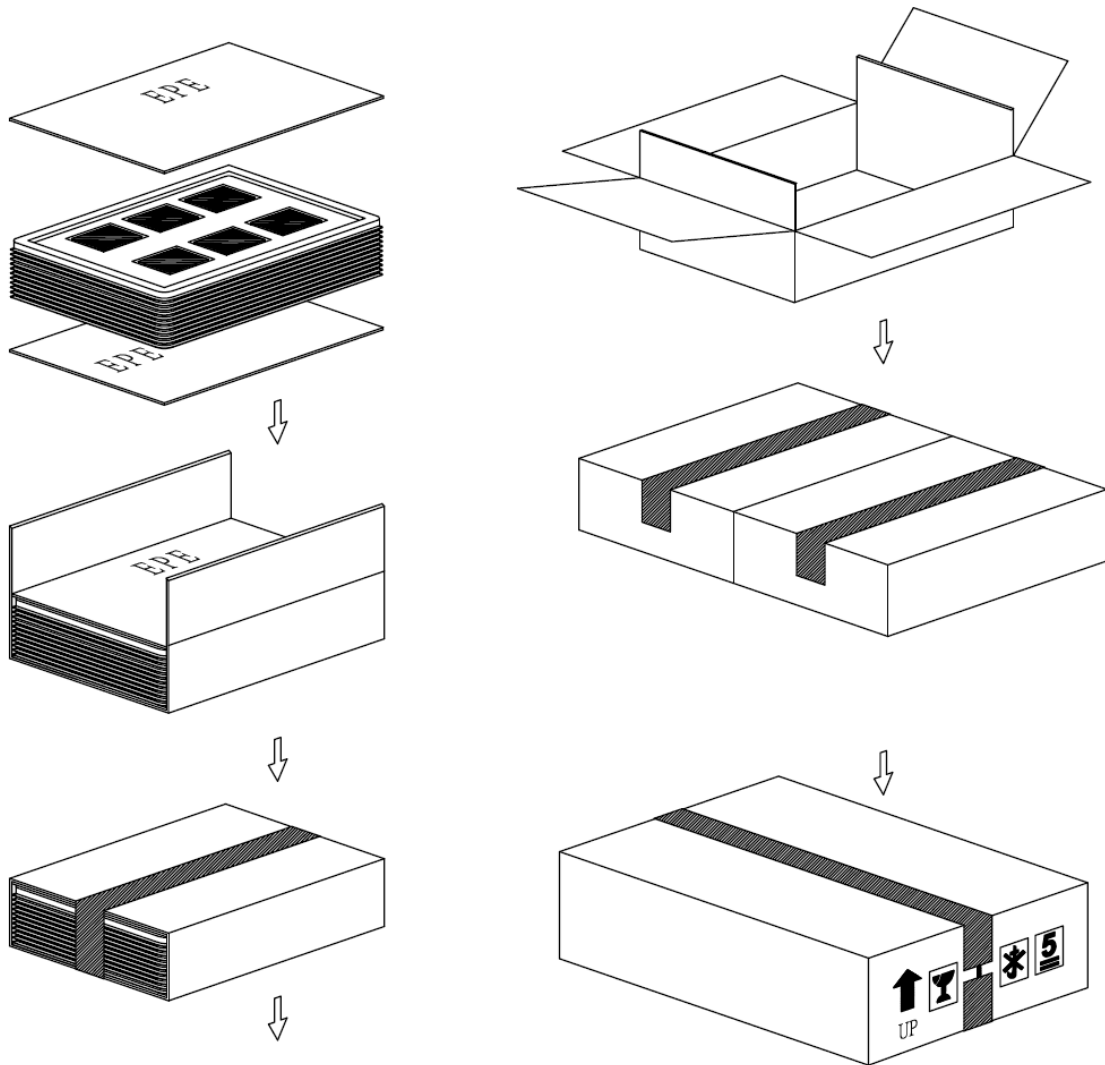

PARTS LIST					
	ITEM	SIZE(LxWxH) unit:mm	MATERIAL	Q.T.Y	NOTE
1	TRAY	372.0x262.0x16.0	PS	28	
2	CARD BOARD(P01)	816.0x375.0x3.5	CARTON	2	
3	CARD BOARD(P02)	945.0x275.0x3.5	CARTON	2	
4	CARD BOARD(P03)	375.0x265.0x3.5	CARTON	4	
5	INTERNAL BOX(S01)	400.0x290.0x150.0	CARTON	2	
6	EXTERNAL BOX(L02)	600.0x420.0x170.0	CARTON	1	
7	PRODUCT	76.9x63.9x4.4		156	



16. Precautions

16.1 Assembly and Handling Precautions

- (1) Do not apply rough force such as bending or twisting to the module during assembly.
- (2) It's recommended to assemble or to install a module into the user's system in clean working areas. The dust and oil may cause electrical short or worsen the polarizer.
- (3) Don't apply pressure or impulse to the module to prevent the damage of LCD panel and Backlight.
- (4) Always follow the correct power-on sequence when the LCD module is turned on. This can prevent the damage and latch-up of the CMOS LSI chips.
- (5) Do not plug in or pull out the I/F connector while the module is in operation.
- (6) Do not disassemble the module.
- (7) Use a soft dry cloth without chemicals for cleaning, because the surface of polarizer is very soft and easily scratched.
- (8) Moisture can easily penetrate into LCD module and may cause the damage during operation.
- (9) High temperature or humidity may deteriorate the performance of LCD module. Please store LCD module in the specified storage conditions.
- (10) When ambient temperature is lower than 10°C, the display quality might be reduced. For example, the response time will become slow.

16.2 Safety Precautions

- (1) If the liquid crystal material leaks from the panel, it should be kept away from the eyes or mouth. In case of contact with hands, skin or clothes, it has to be washed away thoroughly with soap.
- (2) After the module's end of life, it is not harmful in case of normal operation and storage.

16.3 Terms of Warrant

- (1) Acceptance inspection period
The period is within one month after the arrival of contracted commodity at the buyer's factory site.
- (2) Applicable warrant period
The period is within twelve months since the date of shipping out under normal using and storage conditions.



16.4 Cautions for installing and assembling

Bezel edge must be positioned in the area between the Active area and View area. The bezel may press the touch screen and cause activation if the edge touches the active area. A gap of approximately 0.5mm is needed between the bezel and the top electrode. It may cause unexpected activation if the gap is too narrow. There is a tolerance of 0.2 to 0.3mm for the outside dimensions of the touch panel and tail. A gap must be made to absorb the tolerance in the case and connector.

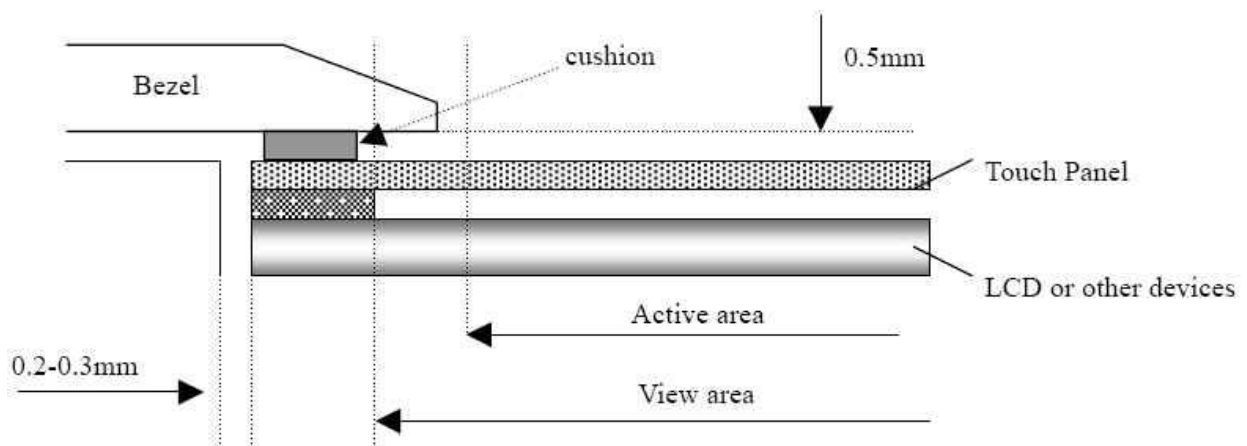

16.5 Operation Prohibit

Not Suggested Pen Input Position On Touch Panel

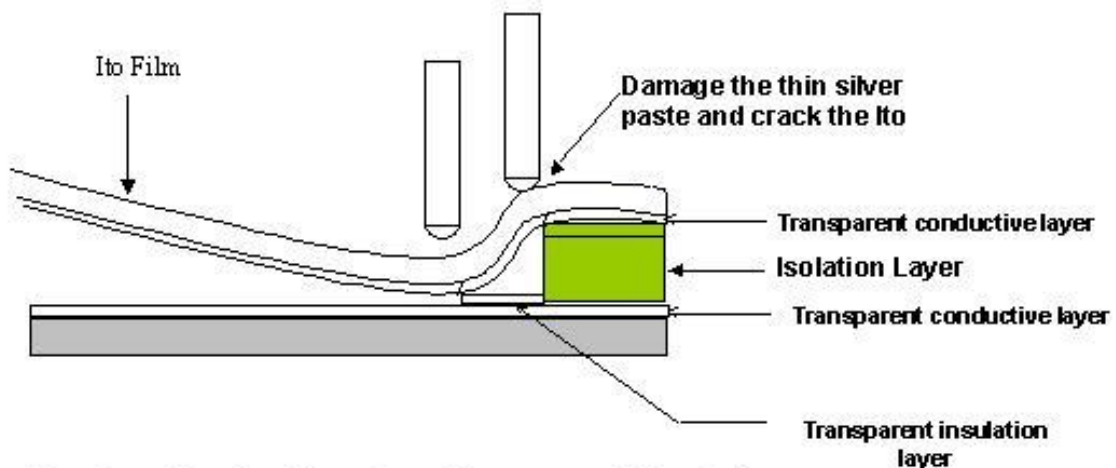

Pen input load on the edge of transparent insulation area might damage the ITO of ITO Pet- Film and reduce the durability of touch panel



P-TEC

MODEL NO.

PT322435B-TLMWD-ER30

SPEC SAMPLE

PAGE

27

17.Outline Drawing

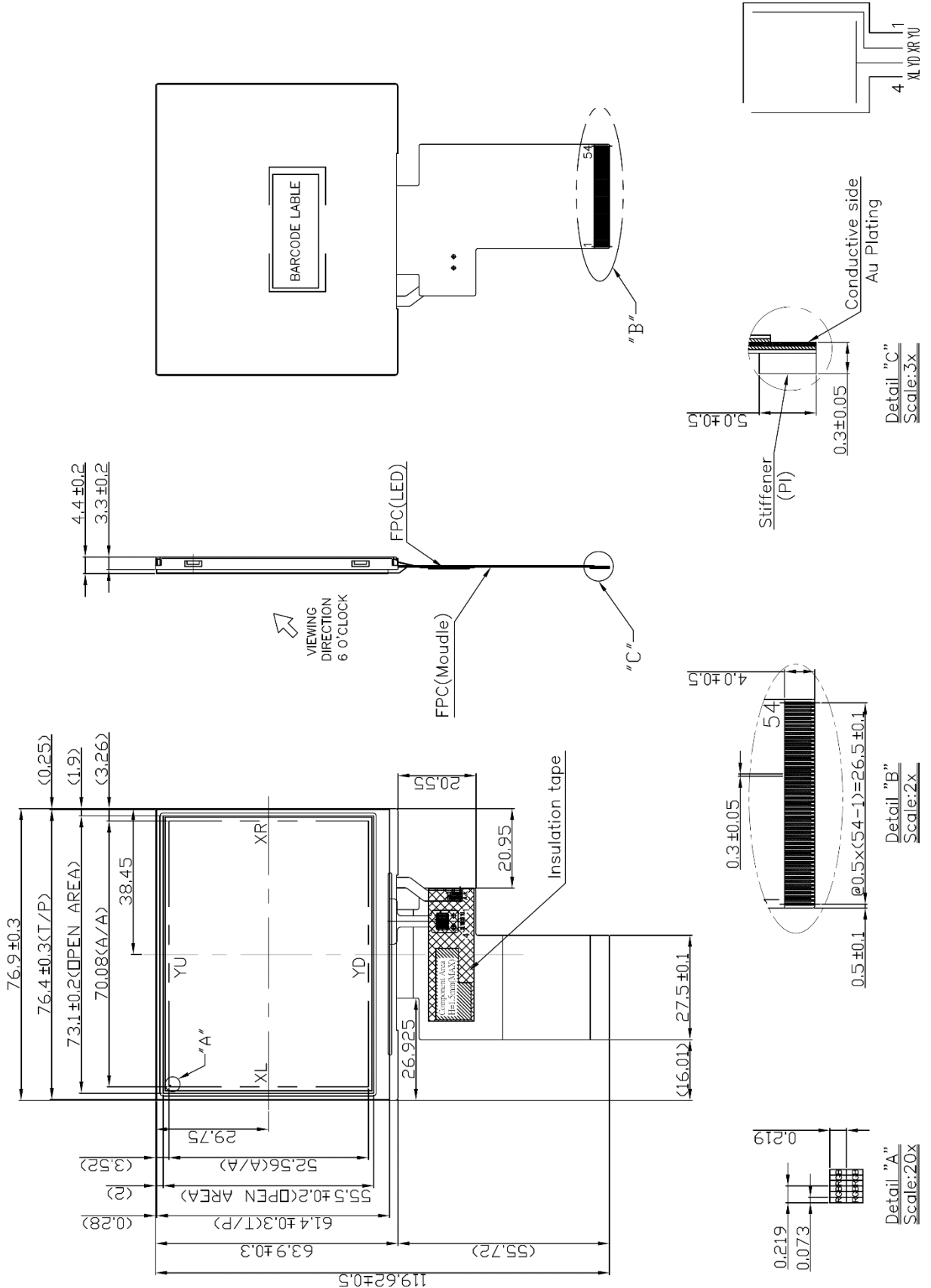



18. Definition of Labels

The bar code nameplate is pasted on each module as illustration, and its definitions are as following explanation.

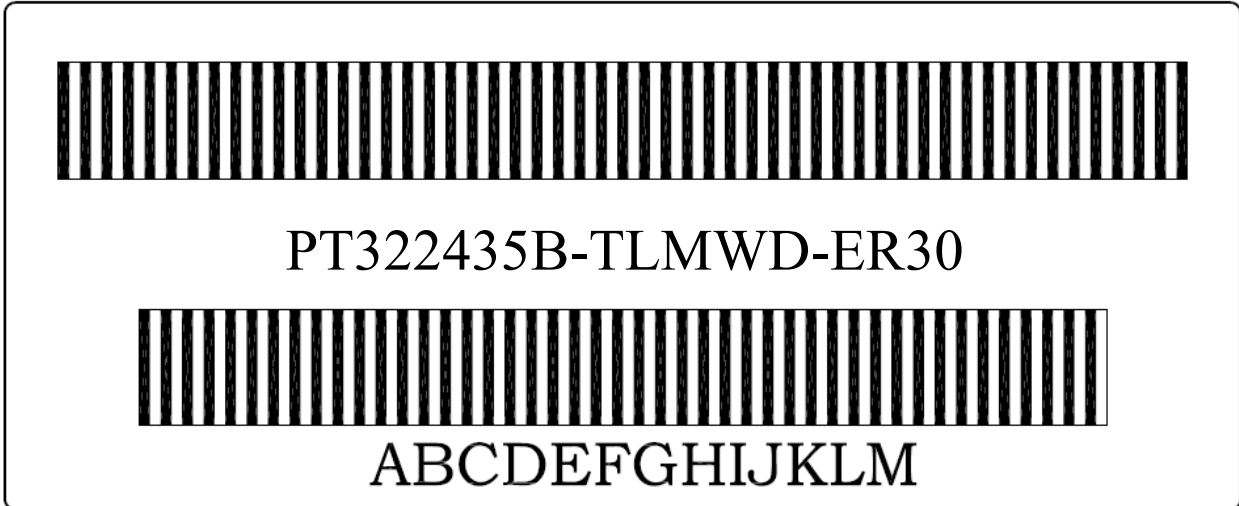

(a) Module Name: PT322435B-TLMWD-ER30

(b) Serial ID:

A B C D E F G H I J K L M

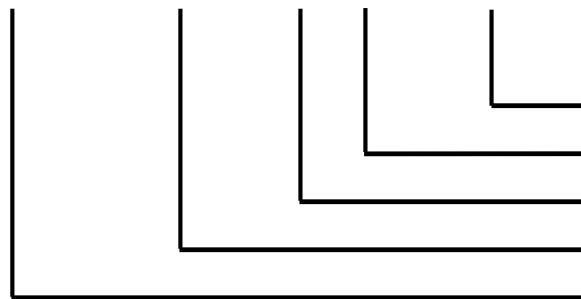

Serial No.
Revision Code
Factory Code
Manufactured Date
Screen Size

Serial ID includes the information as below:

(a) Screen size (Diagonal): Inch Code (ABCD)

3.5" → 0350

10.4" → 1040

(b) Manufactured Date: Year, Month, Day (EFG)

Year (E)

Year	2000	2001	2002	2003	2004	2005	2006	2007	2008	2009
Mark	0	1	2	3	4	5	6	7	8	9



P-TEC

MODEL NO.

PAGE

PT322435B-TLMWD-ER30

SPEC SAMPLE

29

Month (F)

Month	Jan.	Feb.	Mar.	Apr.	May	Jun.	Jul.	Aug.	Sep.	Oct.	Nov.	Dec.
Mark	1	2	3	4	5	6	7	8	9	A	B	C

Day (G)

Day	1	2	3	4	5	6	7	8	9	10	11	12	13	14	15	16
Mark	1	2	3	4	5	6	7	8	9	A	B	C	D	E	F	G
Day	17	18	19	20	21	22	23	24	25	26	27	28	29	30	31	
Mark	H	I	J	K	L	M	N	O	P	Q	R	S	T	U	V	

(c) Factory Code (H):

For P-TEC internal use.

(d) Revision Code (I):

Cover all the change, for example: 1: Rev.1, 2: Rev.2, 3: Rev.3...etc.

(e) Serial No. (JKLM):

Manufacturing sequence of product, for example: 0001~9999.



19. Incoming Inspection Standards

19.1 The environmental condition of inspection

The environmental condition and visual inspection shall be conducted as below.

- (1) Ambient temperature $25 \pm 5^{\circ}\text{C}$
- (2) Humidity: $60 \pm 5\% \text{ RH}$
- (3) Viewing distance is approximately 35 ~ 40 cm
- (4) Viewing angle is normal to the LCD panel as Fig _1(10°)
- (5) Ambient Illumination: 300 ~ 500 Lux for external appearance inspection

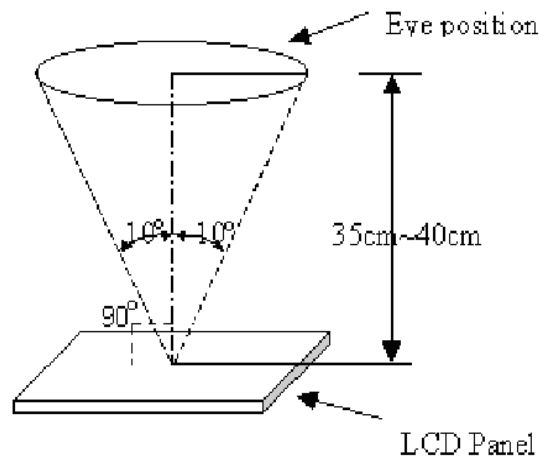

Fig _ 1

19.2 The defects classify of AQL as following:

Class of defects	AQL	Definition
Major	0.65%	It is defect that is likely to result in failure or to reduce materially the usability of the intended function.
Minor	1.5%	It is a defect that will not result in functioning problem with deviation classified.



19.3 Inspection Parameters

Item		Specification/Description			Note	
Display	Function	No Display			-	
		Malfunction			-	
Operating	Contrast ratio	Out of Spec			-	
	Line defect	No obvious Vertical and Horizontal line defect in bright , dark and colored.			-	
	Point Defect (red,green,blue,dark, white)	Item	Acceptable number			Note: 1、4、 5、6
			A	B	Total	
		BRIGHT DOT	$N \leq 0$	$N \leq 2$	$N \leq 6$	
		DARK DOT	$N \leq 2$	$N \leq 4$		
		TOTAL DOT	$N \leq 2$	$N \leq 4$		
TWO ADJACENT DOT		NOT ALLOWED				
THREE OR MORE ADJACENT DOT	NOT ALLOWED					
External Inspection (non-operating)	Scratch on the polarizer	L(mm)	W(mm)	Acceptable number	Note:2	
		$L \leq 2.5$	$W \leq 0.1$	3		
		$L > 2.5$	$W > 0.1$	0		
	Dent or bubble on the polarizer	Dimension(mm)		Acceptable number		Note:3
		$D \leq 0.3$		3		
		$D \leq 0.1$		Disregard		
	Foreign material on the polarizer	Dimension(mm)		Acceptable number		Note:3
		$D \leq 0.5$		2		
		$D \leq 0.1$		Disregard		

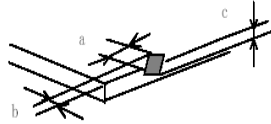
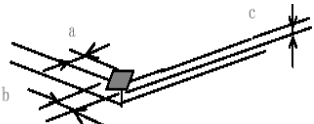

Item		Specification/Description			Note
Touch Panel	Scratch	L(mm)	W(mm)	Acceptable number	Note:2
		L ≤ 10	W < 0.05	Disregard	
			0.05 ≤ W < 0.1	N ≤ 4	
			W ≥ 0.1	0	
	Foreign Materials (Linear shape)	L ≤ 10	W < 0.05	Disregard	Note:2
			0.05 ≤ W < 0.1	N ≤ 3	
			W ≥ 0.1	0	
	Foreign Materials (Circular shape)	Dimension(mm)		Acceptable number	Note:3
		D ≤ 0.25		Disregard	
		0.25 < D ≤ 0.5		N ≤ 6	
D > 0.5		0			
Glass chipping				a ≤ 5mm b ≤ 3mm c ≤ t (t : Glass think)	Note:7
				a ≤ 3mm b ≤ 3mm c ≤ t (t : Glass think)	Note:7
Newton-ring	(In case of doubtful situations) Observe on 60° from the product surface under a white Fluorescent lamp(3-wavelength lamp).			Average diameter ≤ 1/3 Touch Panel area Disregard.	Note:7



P-TEC

MODEL NO.

PAGE

PT322435B-TLMWD-ER30

SPEC SAMPLE

33

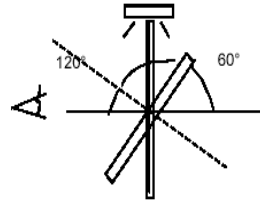

Puffiness

Dimension(mm)

Acceptable number

$D \leq 0.3$

Disregard

Note:8

$D > 0.3$

0



Note1. The definition of dot defect : The dot defect was judged after repair and the size of a defective dot over 1/2 of whole dot is regarded as one defective dot.

Note2.

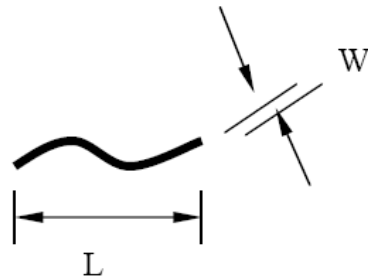

Note3. D : Diameter $D=(a+b)/2$

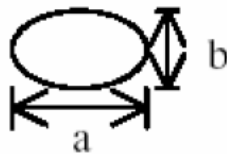

Note4. Bright dot is defined through 6% transmission ND Filter as following.

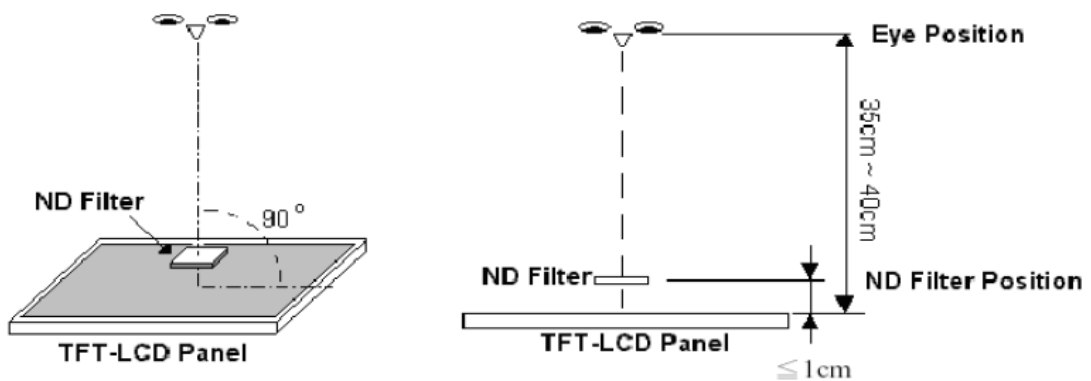

Note5. ADJACENT DOT





Note6.

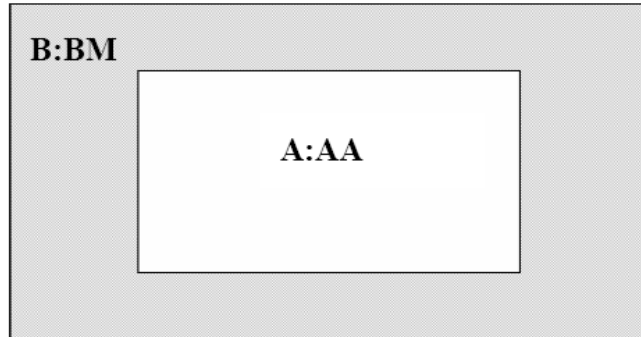

Note7.

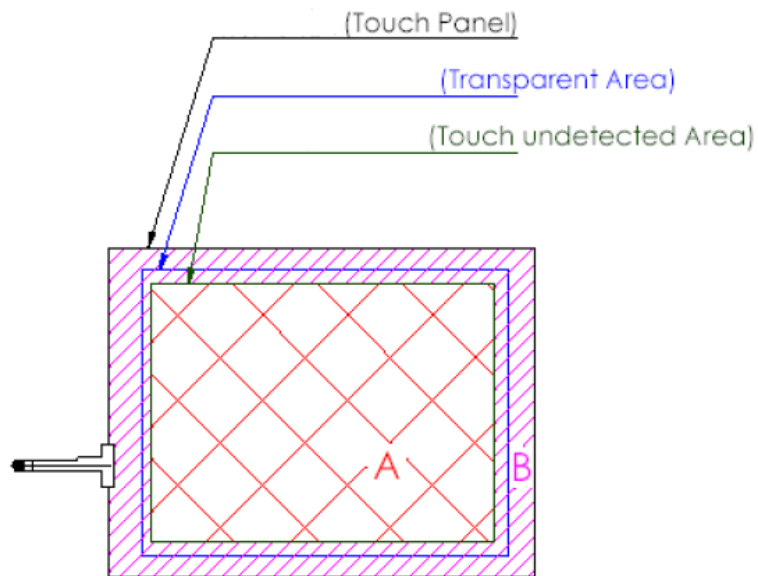

A area : Without any defect point effect on normal operation.

B area : None-specify

Note8.

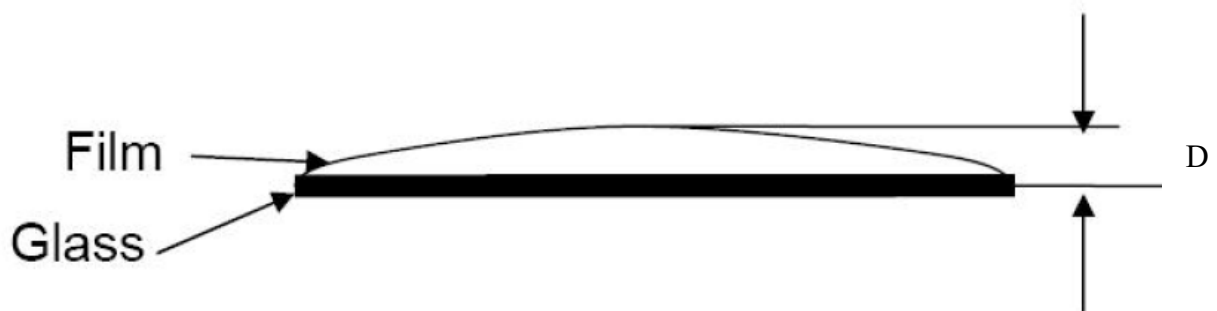



19.4 Handing of LCM

- (1) Don't give external shock.
- (2) Don't apply excessive force on the surface.
- (3) Liquid in LCD is hazardous substance. Must not lick and swallow. when the liquid is attach to your hand, skin, cloth etc. Wash it out thoroughly and immediately.
- (4) Don't operate it above the absolute maximum rating.
- (5) Don't disassemble the LCM.